

# CABLE PROTECT

CABLE CARRIERS (DRAG CHAINS, ENERGY CHAINS, CABLE CONDUITS, CABLE TRACKS)



**|||||HENNIG®**  
cableprotect



Making our customers successful.

Throughout the Industrial world Hennig provides the protection manufacturers need so they can produce at a higher level in a safe, clean and productive environment. Wherever chips are made, there's likely a Hennig product keeping them from becoming a problem.

We know that the road to success of our customers passes through the quality of our work, quick responsiveness and the value we offer. This is why a new mission statement "Making Our Customers Successful" is our company's roadmap to what we want to be and how to get there. Having won our customers' confidence and contributing to their success is not only our final goal, it is a powerful stimulation to improvement and growth. For this reason, we measure our success through our customers.'

## CONTACT US

### WORLD HEADQUARTERS

9900 North Alpine Road  
Machesney Park, IL 61115  
+1 815-636-9900  
+1 888-436-6446 (toll free)  
+1 815-636-1988 (fax)  
info@hennig-inc.com

### EUROPEAN HEADQUARTERS

Hennig GmbH  
Überrheinerstr. 5  
85551 Kirchheim, Germany  
+49 89 96096-0  
+49 89 96096-120 (fax)  
info@hennig-gmbh.de

See pages 27-28 for a complete list of our worldwide locations / contact info





## TABLE OF CONTENTS

3-10	DESIGN GUIDELINES & ARRANGEMENTS
11-18	KOLIBRI SYSTEMS
19-30	PKK SYSTEMS
31-44	SLE STEEL CHAIN SYSTEMS
45-48	STABIFLEX SYSTEMS
49-50	WORLDWIDE CONTACT INFO

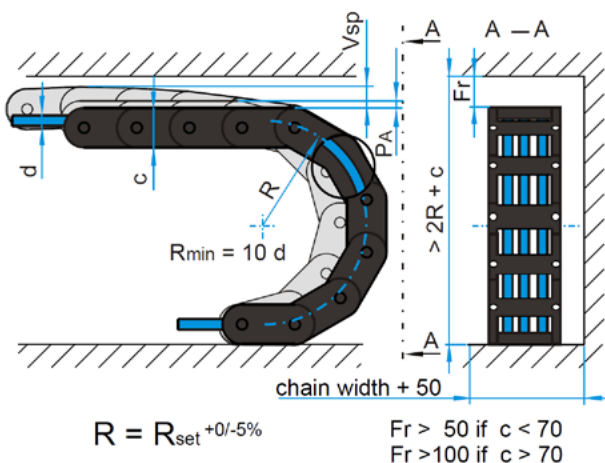
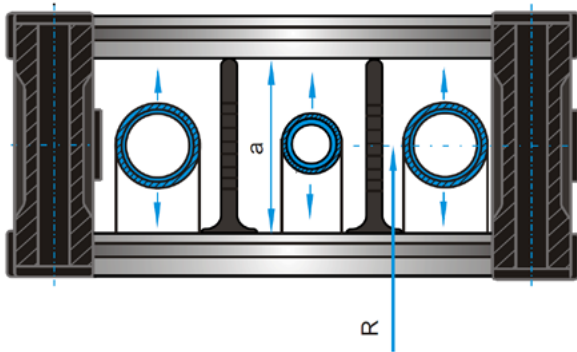
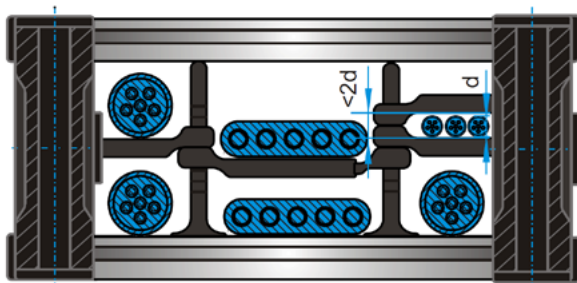
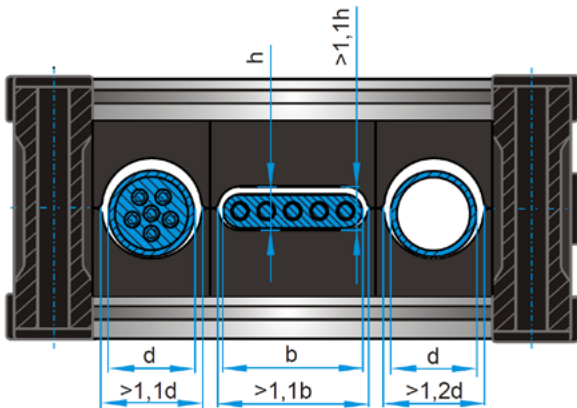

## SELECTION OF THE ENERGY CHAIN AND MATERIAL

For most applications energy chains made of plastic is your first choice. Chemical resistance, light weight and low costs are the major advantages. Steel chains are used under extreme payloads and high mechanical or other particular requirements. For extreme cycles the hardened (carburized) steel is required to achieve long life.

## CALCULATION OF CROSS-SECTION

First, the cross-section required for the wires is determined, and then specific motions or arrangements, aggressive environmental conditions or other factors lead to your selection. A pre-selection of the product series may use the fields of application (see product series chapter). All lines must be able to move freely in the energy chain. This requires an individual clearance to be taken into account for each line:

- round cable:** 10% of the diameter
- flat cable:** 10% of the cable width and height
- hoses:** 20% of hose diameter

Optimum requirement is the separation of all lines by means of individual chambers. Especially with varying diameters or multi-layer wiring a separation by vertical and horizontal dividers is required.

If several lines are to be laid in one chamber, the chamber dimensions have to be restricted so that they maintain their relative positions. Even multi-layer arrangements of flat cables have always to be separated with horizontal dividers.

When using pressure hose a change in length has to be taken into account through additional clearance in the chain bow (radius), which can be achieved by a corresponding chain height (a).

The distribution of the energy chain cross-section should be symmetrical in order to ensure an uniform load. In addition heavy lines are laid out close to the links to minimize the bending loads on the transverse bars.

## DETERMINATION OF THE BENDING RADIUS

The bending radius of the energy chain is determined by the minimum permissible bending radius of the cables and hoses, the available installation space and the polygon oscillation PA of the energy chain. In general, a minimum bend radius of  $10d$  is considered, where  $d$  is the largest existing line diameter. Cables with smaller minimum bend radii are available by some manufacturers.

The polygon oscillation PA influences the moving of an energy chain. A large bend radius at the same pitch results usually in a calmer movement of the energy chain. The installation space must have a height of more than  $2R + c$ , where  $R$  is the set-radius and  $c$  is the link height of the energy chain. The real radius is the set radius  $+0/-5\%$ . The pretension of the energy chain should also be considered.

## CABLE CARRIER LENGTH

In standard applications the fixed connector of the energy chain is arranged in the middle of the travel distance. The moving connector moves horizontally over the fixed connector between the end positions of the travel. The required length of the energy chain between the first and the last pivoting link is then determined as follows:

$$L = LV/2 + 4 R$$

- L length of the energy chain
- LV length of travel
- R bending radius of the energy chain

If the fixed connector is not in the middle of the travel, the energy chain has to be extended by a displacement of x:

$$L = LV/2 + 4 R + x$$

- x offset of the fixed connector

After the selection of the energy chain, the length is rounded up to the link pitch. This length is the ordering length of the energy chain. The connectors height is double bend radius plus link height:

$$HA = 2 R + c$$

- HA connector height
- c link height of the energy chain

## REVIEW OF THE FREE CARRYING LENGTH

The additional load is the weight of all cables and hoses, divided by the length of the chain:

$$ms = mL/L$$

- mL cable weight
- mS specific additional load

Thus with calculated additional load and the help of the load diagram the free carrying length of the energy chain can be verified.

If the additional load is too high for a particular chain an energy chain with greater free carrying length is chosen or constructive changes have to be done that allow the operation with the chosen energy chain (eg, gliding arrangement, support rollers, SYSTEM MARATHON or similar).

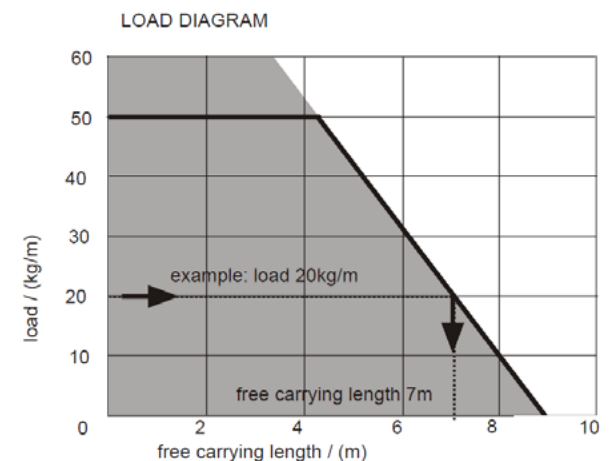
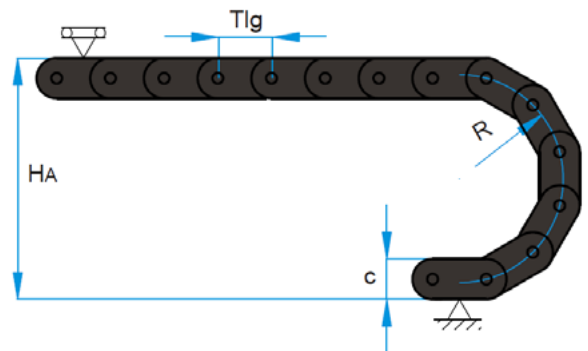
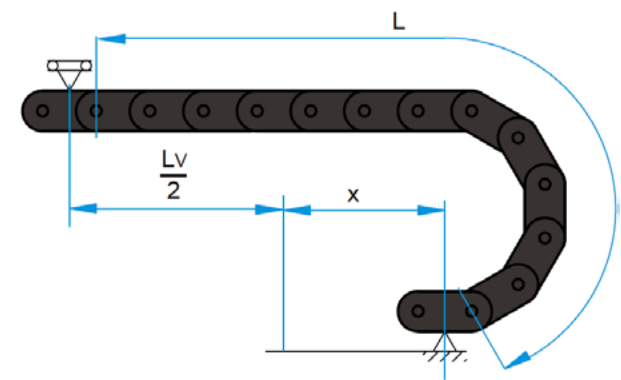
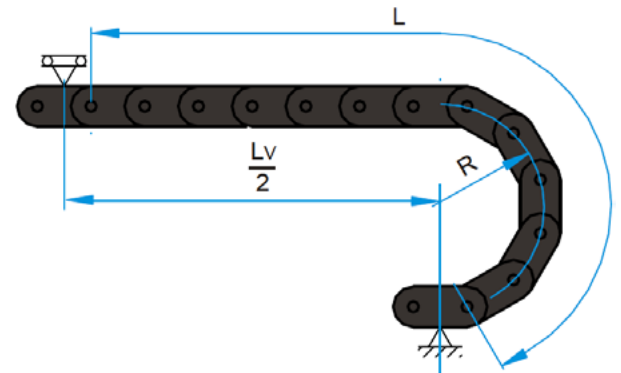

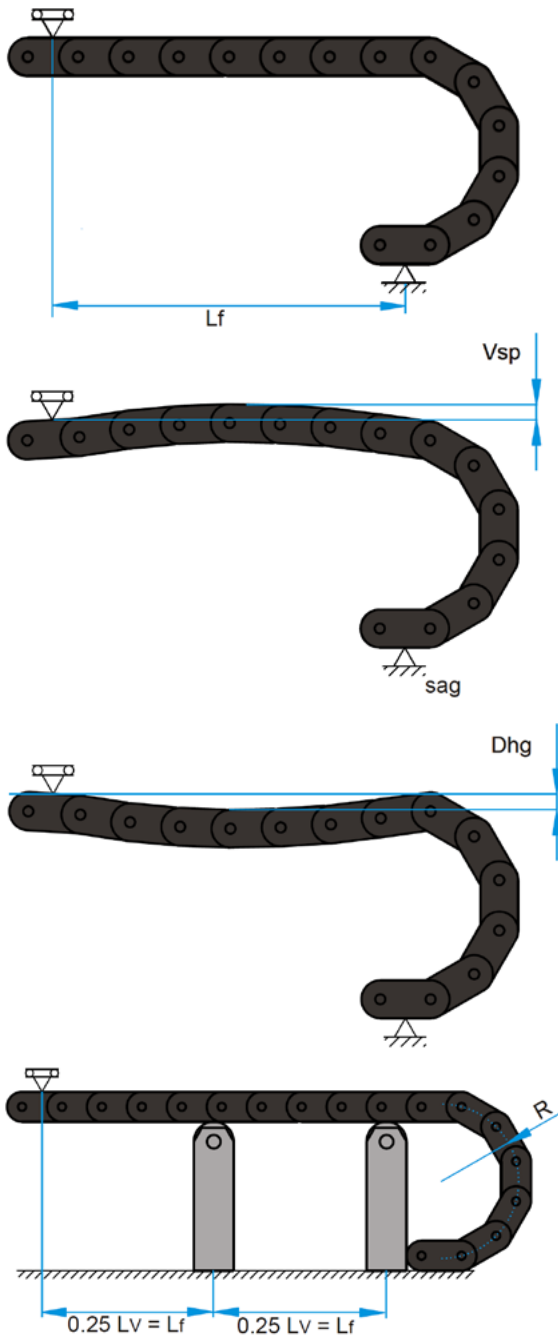

## PRETENSION AND PERMISSIBLE SAG

Energy chains are supplied with pretension. Exceptions are energy chains for vertical or sliding arrangements as well as on the side lying energy chains, for example, in a circular arrangement.

The pretension is a manufacturing tool to achieve energy chains with increased free carrying lengths. The values for the pretension is set by the manufacturer. Our energy chains made of steel are manufactured with 5 mm / m and plastic energy chains up to 25 mm / m as pretension with no load.

The sag is due to the additional load and the weight of the energy chain. Due to the significantly lower elongation of steel (0.2% linear elongation) compared to plastics the permissible sag of the steel chains is limited lower than for plastic energy chains.

On the other hand, the effect on plastic energy chains of a long-term static load with a long unsupported length of the upper strand chains will increase the sag (creeping of plastics). Elevated temperatures and humidity increases this effect. The sag of energy chains is also increased by use-wear.

The maximum allowable sag can only be judged in the assessment of all operating conditions. Within the limits for the free carrying length specified in the load diagram the sag is within the permissible range at normal operating and environmental conditions.

In addition the following factors have to be taken into account: Using toughs and slow moving energy chain sag is limited.

For high accelerations and high travel speeds too much sag is a problem. A defined force application at the moved connector is not guaranteed and uncontrollable chain oscillations can occur. Thus the energy chain material is subjected to extreme dynamic stresses. In such cases, corrective steps should be taken.

The first step is the selection of an energy chain with increased free carrying length. If this can not be done, see page 6 for alternatives.

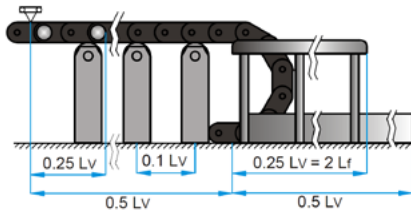

## SUPPORT ROLLS AND SUPPORT RAILS

Support rollers can increase the maximum travel LV of steel chains by up to four times the free carrying length Lf. With additional support rollers and a support rail the maximum range of movement can be expanded up to eight times the free carrying length. The use of support rollers with support frames, is limited to speeds below 1 m / s.

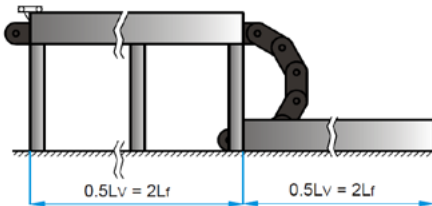

## RAISED TROUGH

This type is mainly used with plastic energy chain applications. As with the use of support rolls the maximum travel can be increased up to four times the free carrying length. Because of the larger permissible sagging, support rolls are not suitable for plastic energy chains.

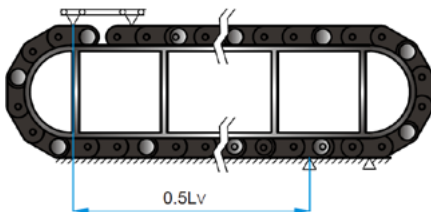

## SUPPORT CARRIAGE

For long travel distances and high additional loads support carriages can be used with reverse traveling energy chains. The side-mounted support rolls carry the energy chain and move the support carriage. The energy chains now only face pull forces and through this an extremely long life is achieved even at high additional loads.

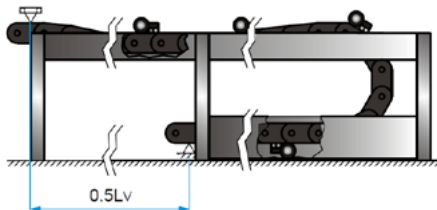

## SYSTEM MARATHON

The patented SYSTEM MARATHON for unlimited travel is also designed for high speeds and high accelerations. The upper run is running with supporting rollers over the entire travel on continuous flat rails and the rollers swing in the radius to lay down the energy chain at the bottom profile. In the back movement the rollers swing out again and lead the energy chain without wear over the entire travel. The SYSTEM MARATHON is not dependent upon the type of energy chain and therefore steel energy chains are as equally suitable as plastic energy chains.

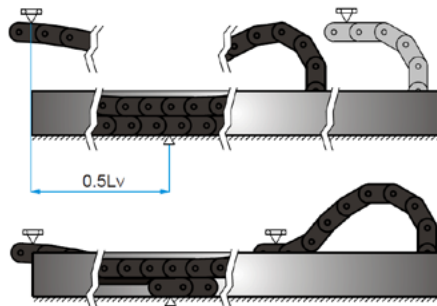

## GLIDING ENERGY CHAINS

Gliding energy chains require guiding the upper run in a continuous trough. In addition, the first half of travel slide bars are mounted or the energy chain is extended via the fixed end in the middle of the travel out up to the starting point to create a continuous gliding plane (see also chapter troughs).

With high dynamic demands on the energy chain, lowering the moving connection end may be necessary to result in a better introduction of push forces into the energy chain. In travels over 30 m, velocities above 1.5 m / s and acceleration of 1 m/s<sup>2</sup> lowering the moving end is recommended and requires an additional length of the energy chain. Chain links with a opposite bend radius minimize the required additional length and minimize oscillations of the remaining free carrying length of the energy chain.

PKK, PLE and SLE energy chains for gliding arrangements are preferably equipped with sliders that can be replaced after reaching the wear limit without dismantling or replacing the energy chain.

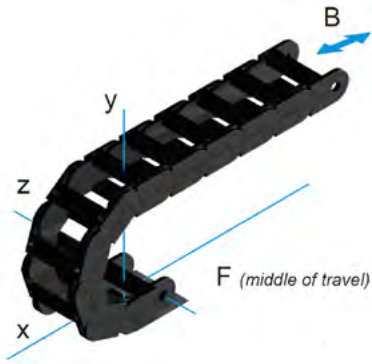

## NORMAL ARRANGEMENT (N)

In the normal arrangement the fixed connector is usually on the first link in the lower strand in the middle of the travel. The moving end connector is moving the chain in a straight line lengthwise at a height of  $2R+c$  over the entire travel. The upper strand is steadily reduced through the bending of the individual links until the whole chain length is taken to the bottom or in a trough.

This arrangement allows maximum speeds and extreme acceleration with optimum durability.

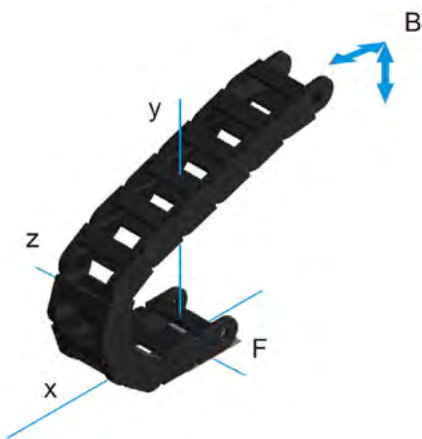

## MULTIAXIAL (M)

In the multiaxial arrangement is a vertical and horizontal motion of the driver along the x-axis (travel direction) and one or more movement in the y- or z-direction. While running in the y-direction may be done by any conventional energy chain, the movements in the z-direction require the energy chain system ALLROUND.

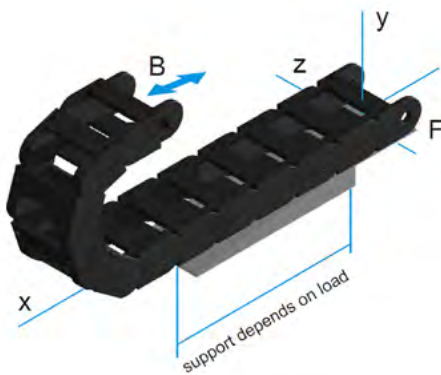

## FREE OVERHANG (F)

In contrast to the normal arrangement the freely exceeding lower strand is supported only partially by a substructure. Due to the high weight load on the lower strand in this arrangement only significantly reduced travel distance is possible.

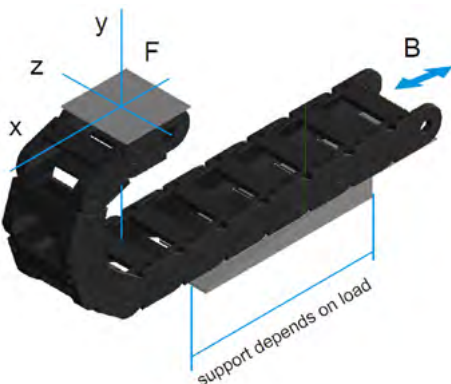

## MOVED END DOWNSIDE (U)

If the driver is positioned in the lower, due to the heavy weight only a reduced travel distance is possible (see above).



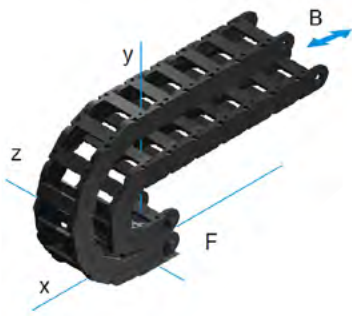

## NESTED TRAVEL (I)

The arrangement of two or more energy chains with different bending radii or even different energy chains makes sense when using a variety of cables and hoses together. The energy chains are moved together by a common driver.

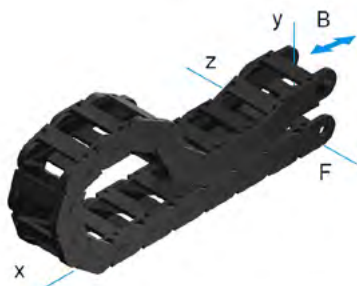

## GLIDING ARRANGEMENT (L)

If the free carrying length is exceeded, the energy chain changes into a gliding state. In this arrangement, use energy chains without pretension. A trough is required (see chapter troughs). Sliders increase the lifespan and can be replaced if necessary.

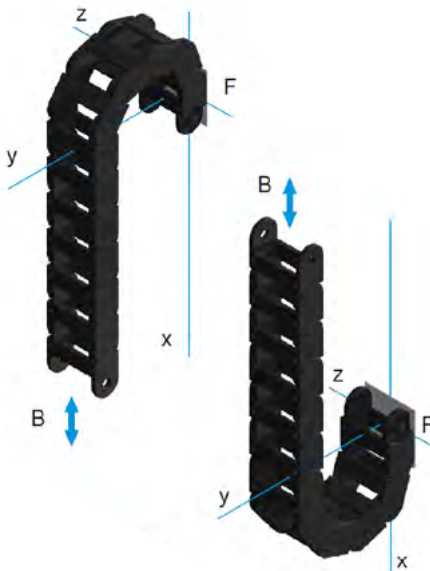

## VERTICAL TRAVEL (S)

Vertical travel arrangements are often installed in systems in which multiple linear axes are coupled. In this arrangement usually energy chains without pretension are used. Vertical arrangement with multiaxial movement needs chains with pretension. The weight of the lines and of the energy chain has to be placed and pushed by the straight part of the chain. This forces should be caught by a supporting. The energy chain should be arranged so that optional cross accelerations are in the y-direction

## VERTICALLY HANGING (H)

Elevators, high-bay stores and doors are typical applications for energy chains in vertically hanging arrangement. In this arrangement the energy chain is predominantly tensile stressed. Lateral acceleration should be layed if any, in the y-direction. Energy chains are without pretension.

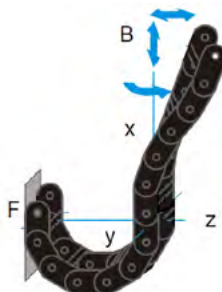

## HANGING MULTIAXIAL (HM)

The energy chain ALLROUND provides the combination of linear and rotary motion.

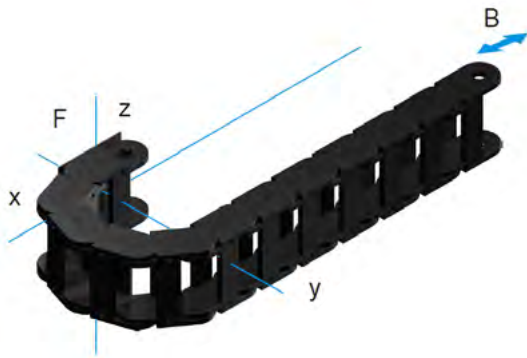

## HORIZONTAL (W)

(on the side)

Energy chains are arranged horizontally lying on their side, for example, if the space does not allow a normal arrangement. In some cases, lying on its side provides an alternative for very long traverse at low speeds and strokes. In this application mainly chains without pretension are used. In general, suitable guide troughs and gliding discs or rollers are required.

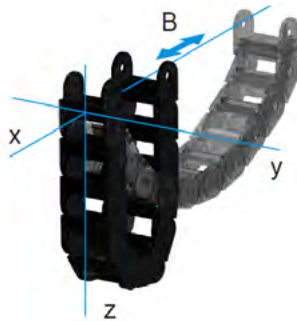

## DRIVING APART (A)

With energy chains moving apart the calculation of the energy chain length does not follow the usual pattern, but be adapted to the individual requirements of the application.

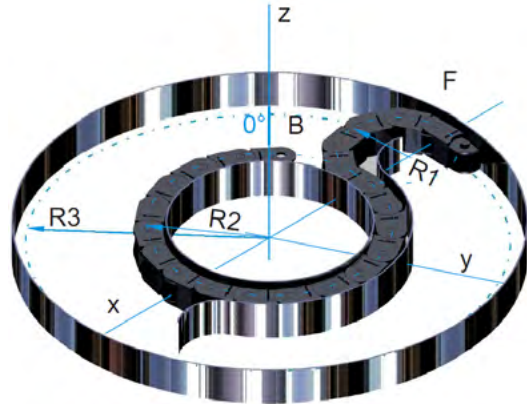

## CIRCLE (K)

(on the side)

The circular motion is a special form of chain movement. For circle movement a part of the energy chain has to be manufactured with an opposite bending radius R2. The outer radius R3 is derived from the link height, the bending radius of the energy chain R1 and the opposite radius R2.

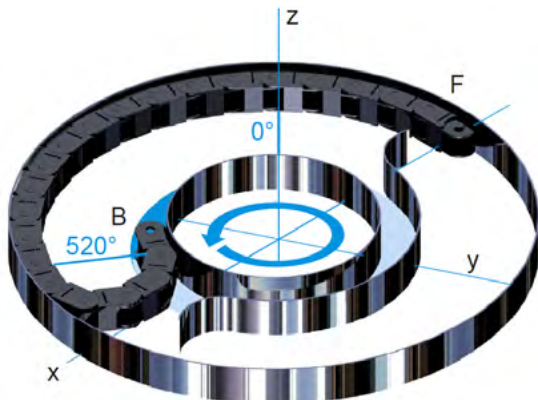

This type of horizontal arrangement allows rotation up to 520 °. A customized guide channel is required.

Energy chains are arranged horizontally lying on their side, for example, For laying in energy chains only highly flexible cables with permissible bending radii and sufficient dynamic capacity suitable. The cables have to be laid twist free to move freely lengthwise. Cable on a reel should be unrolled in the reverse winding direction and placed in the extended state in the energy chain. For intermediate storage the lines are ideally laid out straight. The material relaxation occurs in this case facilitates a twist-free installation.

The distribution of the chain interior must prevent mutual interference between the wires with dividers or wrap clamping of different diameters safely, so that each line can move freely in the longitudinal direction (see design guidelines). In particular in the energy chain radius tensile stressed wires increase wear drastically and reduce the reliability. A fixation of the wires or a bundle of several lines using cable ties or the like within the energy chain can also cause damage.

## STRAIN RELIEF

With long travel distances and high speeds the cables should be attached with strain relief only at the driver end. For free carrying energy chains recommend for aesthetic reasons, a strain relief on both ends. The distance of strain relief to the bending stressed area depends on the particulars of the line manufacturer. Hydraulic hoses have special needs.

## INTEGRATED STRAIN RELIEF

In this space-saving type the strain relief is directly attached to the plastic dividers (PZ) in the first link of the energy chain (note the mounting direction of PZ!). In order to avoid premature line wear caused by dynamic loads, a small excess length of the chain is recommended .

## COMBINED STRAIN RELIEF

The combined strain relief combines the advantage of a sufficient distance from the bending line areas to the strain relief by the simple and space-saving installation of the integrated strain relief. The anchor profile is provided to the drilling dimensions of the energy chain and attached to the chain. The lateral insertion and extraction of strain relief elements is through the C-profile.

## SEPARATE STRAIN RELIEF

The separate strain relief is recommended for high dynamic loads and large line diameters. A sufficient distance of the strain relief to the moved line areas and length compensations are easy to implement. In this variant the lateral insertion and extraction of the strain relief elements with no installation work on the cable carrier is possible.

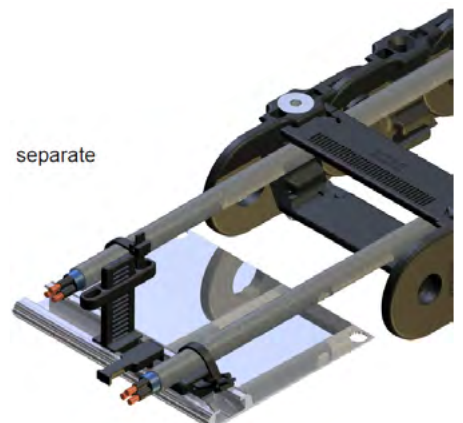
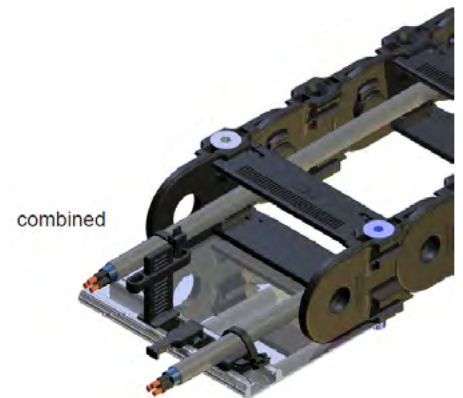
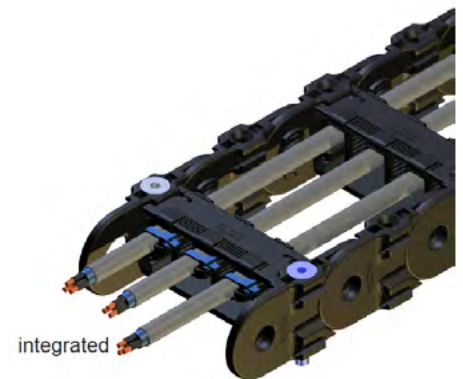
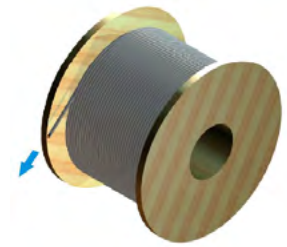

# KOLIBRI PLASTIC CABLE CARRIERS



## KOLIBRI FEATURES

- Inexpensive energy chain for light-weight applications.
- Robust design
- Easy access by flap stays. Extremely rigid and wear resistant.
- The patented opening offers high rigid torsion behavior and comfortable handling in one.
- Unique separation with the pinch stays smallest dimensions.
- Mounting brackets not needed. All plastic energy chains are equipped with integrated mounting holes
- Smooth motion. No "break in time" needed



## APPLICATIONS

**robotics**

**handling**

**transportation**

**paper production**

**textile industries**

**water plants**

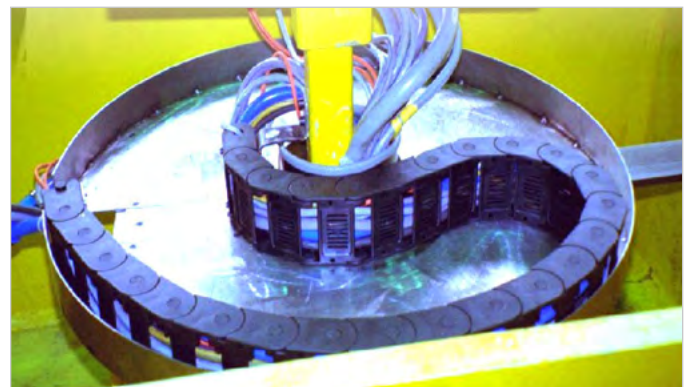
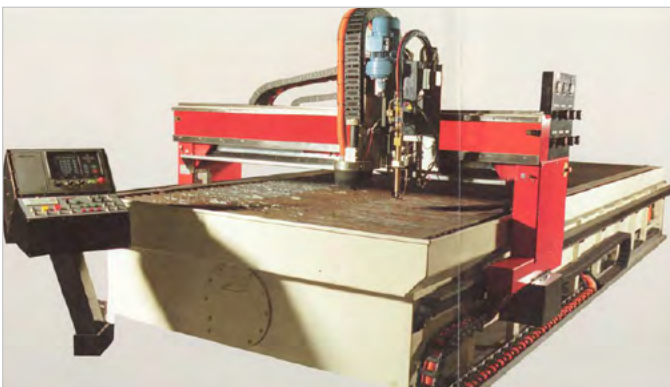

# KOLIBRI PLASTIC CABLE CARRIERS

## LOAD DIAGRAM

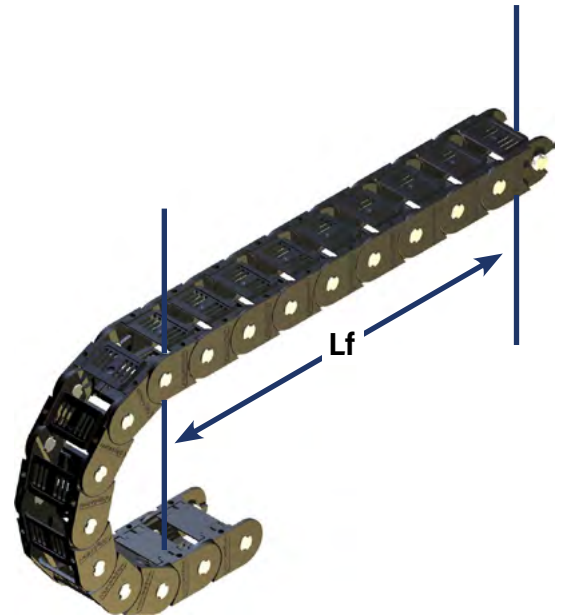
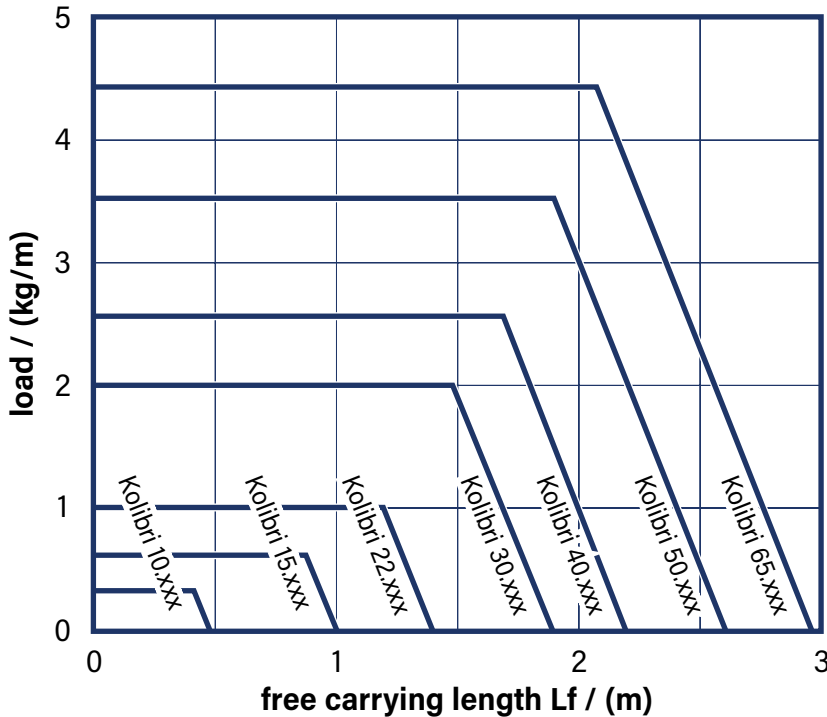

## DIMENSIONS

**bending radii:** 15 - 400 mm  
**inner height:** 7 - 50 mm  
**inner width:** 7 - 195 mm  
**weight:** 0.06 - 2.7 kg/m

## TEMPERATURE

Long term temperature limits are between -20°C and 100°C.

## SPECIAL VARIANTS

**ELTOLA:** silent running  
**ATEX:** EX-protection  
**ESD:** antistatic  
**V-0:** self extinguishing

## TRAVEL DISTANCE

The maximum travel distance is given by the arrangement and the load (weight of the lines). At normal arrangements the maximum travel distance is double the free carrying length. Support rollers or similar equipment may exceed this value.

In gliding arrangements travel distances up to 100 m are possible (according to the application).

For longer travels see chapter on design guidelines.

## TRAVEL SPEED

There are no limits for the travel speed in general. But with gliding arrangements application specific influences have to be taken into account.

## ACCELERATION

There are no limits for the accelerations, in general. Limits may occur through the tensile stresses at high line weights.

# KOLIBRI PLASTIC CABLE CARRIERS | TYPES

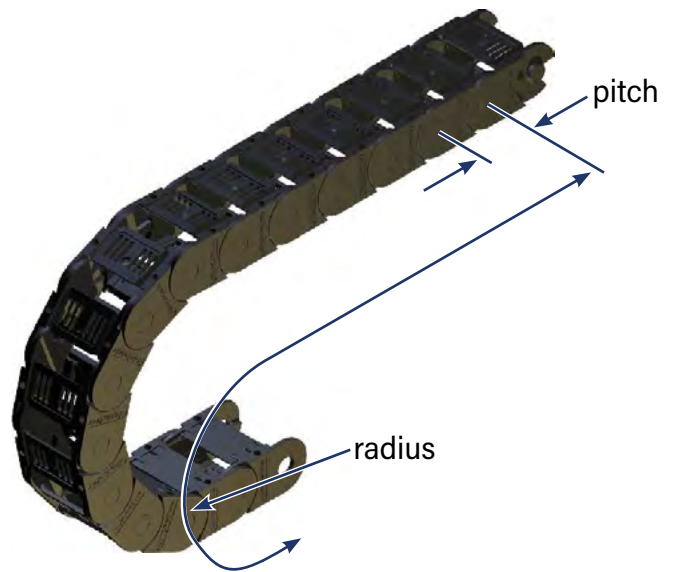
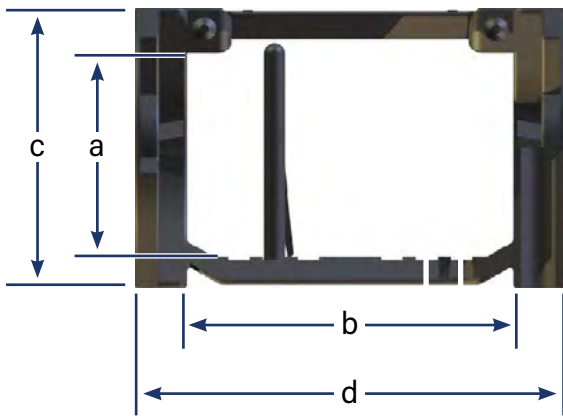

**Kolibri 00.000.0**  
**standard type**  
 flap open bars in inner radius  
 separable with pinch stay  
 integrated connector



**Kolibri 00.000.4**  
**film stay**  
 film stay in inner radius  
 not separable  
 (integrated connector)



**Kolibri 00.000.1**  
**openable in outer radius flap**  
 open bars in outer radius  
 separable with pinch stay  
 integrated connector



**Kolibri 00.000.5**  
**closed type**  
 flap open covers in outer  
 radius separable with pinch  
 stay integrated connector



**Kolibri 00.000.2**  
**rigid version**  
 flap open bars in inner radius  
 separable with PZ integrated  
 connector



**Kolibri 00.000.6**  
**equal .2**  
 flap open bars in  
 outer radius



**Kolibri 00.000.3**  
**one part chain links**  
 not openable not separable  
 integrated connector



**Kolibri 00.000.7**  
**telescopic type**  
 PKK stays in inner radius  
 separable via Pz separate  
 connectors

# KOLIBRI PLASTIC CABLE CARRIERS | DIMENSIONS

Kolibri type	pitch	dimensions				radius	weight kg/m
		a	b	c	d		
10.012.4	15	Ø7	Ø7	10	12	15, 30, 50	0.05
13.023.4	20	9	14	13	23	17.5, 35	0.12
15.015.3 .4	20	Ø10	Ø10	15	15	17.5 <sup>2)</sup> , 20, 30	0.15
15.036.5	18	10	25	15	36	30, 50	0.30
15.037.3	20	10	24	15	37	24, 30	0.30
15.051.0	20	10	39	15	51	20, 30	0.35
22.025.4	30	17	15	22	25	35, 70, 100	0.20
22.038.0 .1	26	17	27	22	38	35, 50, 60, 70, 100	0.34
22.048.0	30	17	36	22	48	35, 70	0.37
22.060.5	26	16	48	22	60	50, 70, 100	0.54
30.030.3	40	24	18	30	30	40, 100, 200	0.50
30.060.3	40	24	48	30	60	40, 100, 150, 200	0.60
30.050.0 .1 .5	35	23	34	30	50	40 <sup>1)</sup> , 60, 75, 100, 150, 200	0.54
30.060.0 .1	35	23	44	30	60	40, 50, 75, 100, 150, 200	0.61
30.080.0 .1 .2 .4 .5	35	23	64	30	80	40 <sup>1)</sup> , 60 <sup>4)</sup> , 75, 100, 150, 200	0.65
30.095.0 .1	35	23	79	30	95	40, 75, 100, 125, 150, 200	0.75
30.125.0 .1	35	23	109	30	125	40, 75, 100, 150, 200	0.87
40.062.2 .5	45	29	48	40	62	60 <sup>1)</sup> , 75, 100, 150, 200	0.91
40.075.2 .6	45	29	60	40	75	60, 75, 100, 150, 200	1.05
40.112.7	37	31	50	100	-	55	1.05
50.065.0 .5	55	40	48	50	65	75 <sup>1)</sup> , 100, 125 <sup>1)</sup> , 150, 200, 250	1.30
50.095.0 .1 .2 .5	55	40	78	50	95	75 <sup>1)</sup> , 100, 125 <sup>1)</sup> , 150, 175 <sup>1)</sup> , 200, 250	1.35
50.125.0 .1	55	40	108	50	125	75, 100, 125, 150, 200, 250	1.52
50.150.0 .1 .5	55	40	133	50	150	75 <sup>1)</sup> , 100, 150, 200, 250	1.90
65.095.1 .5	70	50	77	65	95	125, 150, 200, 300	2.20
65.135.1 .5	70	50	117	65	135	125, 150, 200, 300 <sup>3)</sup>	2.60

1) not Kolibri xx.xxx.5

2) only Kolibri 15.015.3

3) additional R400

4) only Kolibri 30.080.5

# KOLIBRI PLASTIC CABLE CARRIERS | SIZES

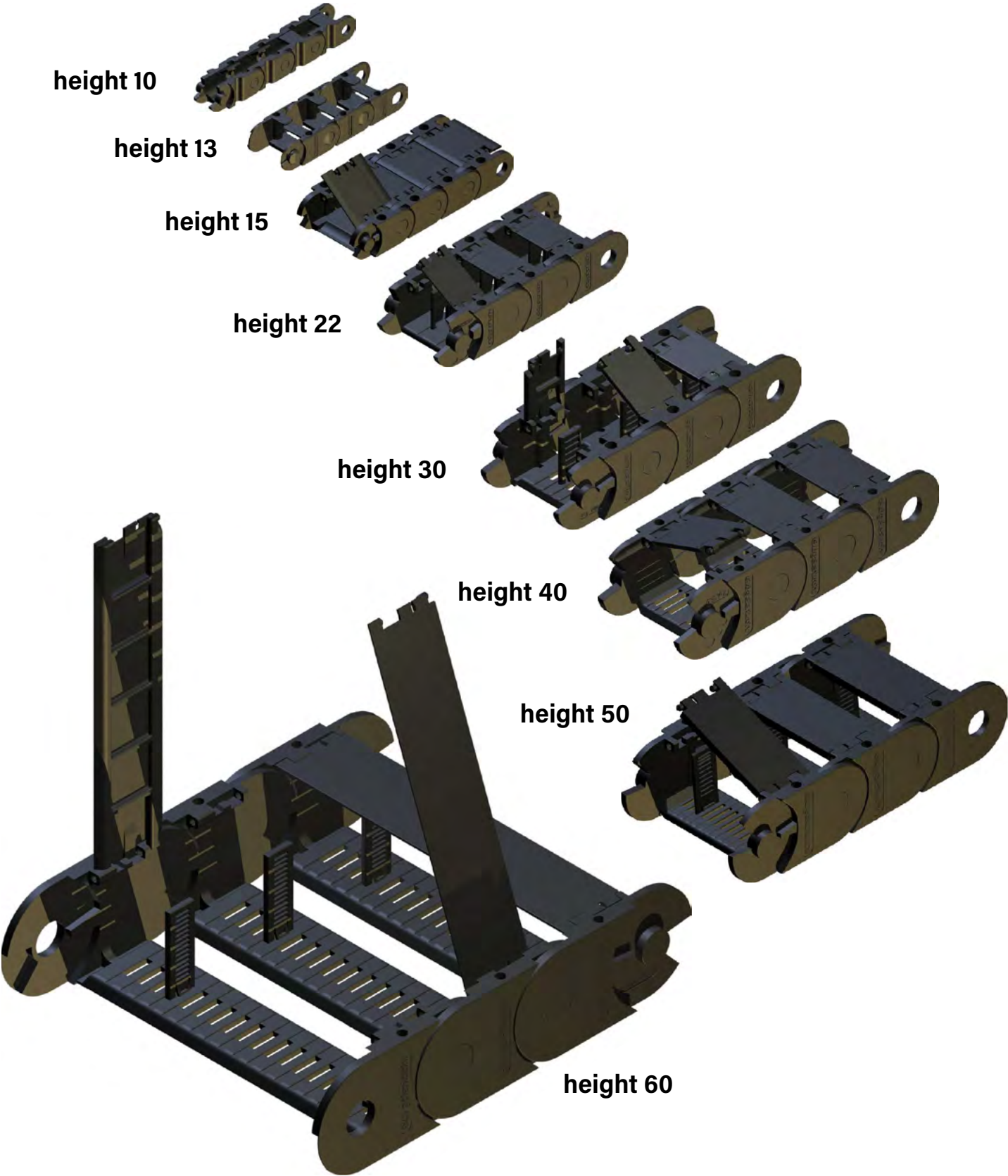

height 10

height 13

height 15

height 22

height 30

height 40

height 50

height 60



# KOLIBRI PLASTIC CABLE CARRIERS | PARTS

- 1 link (open type)
- 2 link (closed type)
- 3 flange pivot
- 4 flange drilling
- 5 horn stay connector
- 6 horn stay 65 HS65
- 7 horn stay 85 HS 85
- 8 damping element
- 9 PZ (divider)
- 10 PZ (pinch stay)
- 11 flap stay
- 12 flap cover
- 13 notched horizontal divider
- 14 notched horiz. divider flying
- 15 telescopic horizontal divider
- 16 telescopic horiz. divider flying
- 17 ladderstay
- 18 connector 10.012.4 hole
- 19 connector 10.012.4 pivot

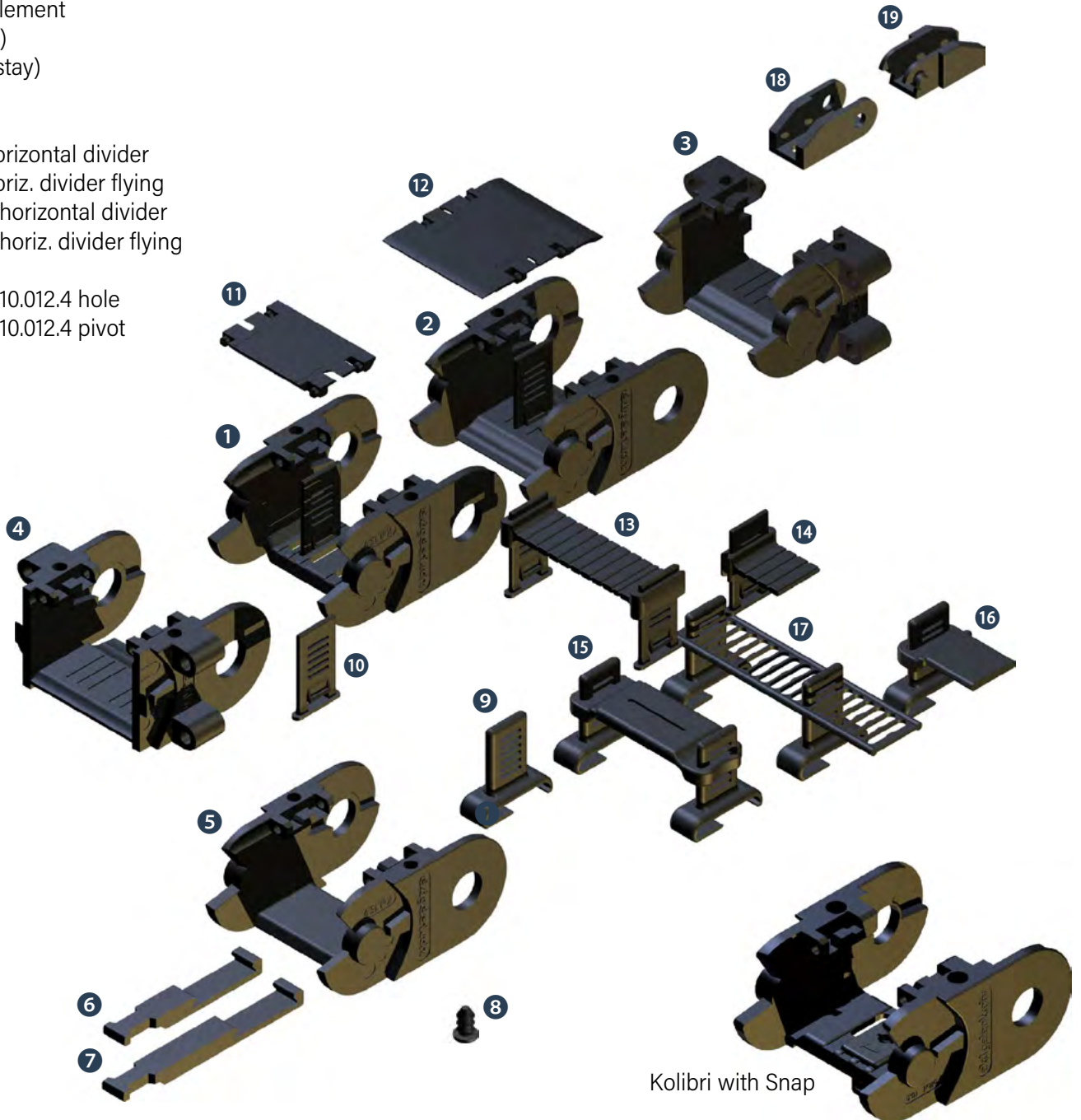

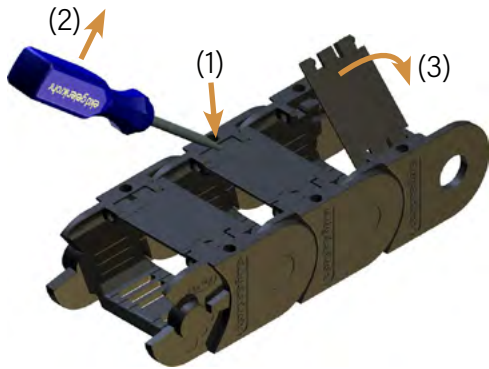

## OPENING AND CLOSING

Push a screwdriver as shown in the slot (1) then with a light lever movement (2) raise the tongue and push the locking pins of the flap stay (or the flap cover) out of the drilling. The flap stay can then be lifted (3). To remove the flap stay the second side has to be unlocked and the stay has to be pushed out against the direction of the cones.

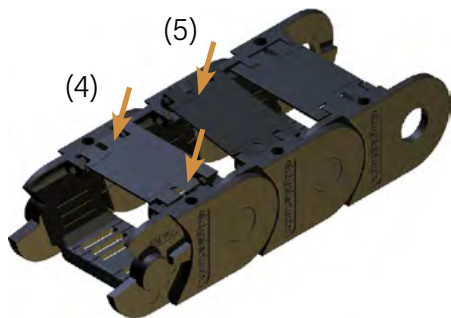

The installation of the flap stays and flap covers are snapped in a slight angle with the pins against the corresponding drillings (4) and with slight pressure against the locking tongue. Lifted flap stays can be re-engaged (5) with slight pressure.

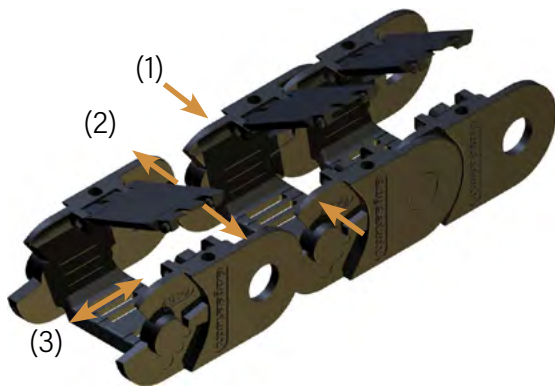

## LENGTHENING AND SHORTENING

To lengthen or shorten the flap stays have to be opened. The walls with pivot pins are to press internally (1) and the walls with the holes are to press toward the outside (2). The chain links can be pushed together (3), or be pulled apart.

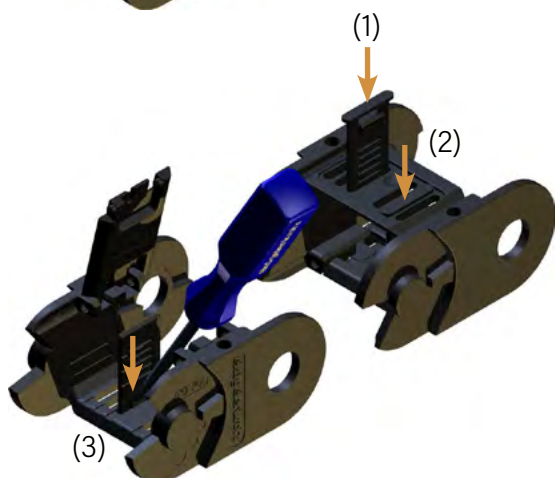

## INSTALLATION OF THE FLAP STAYS

The assembly of the flap stays can take place before or after cable lining. Therefore energy chain does not need to be opened. The flap stays are inserted from the outside chain link floor until snap (1), (2). The dismantling of the stays is done by unlocking the tongue and pushing out (3).

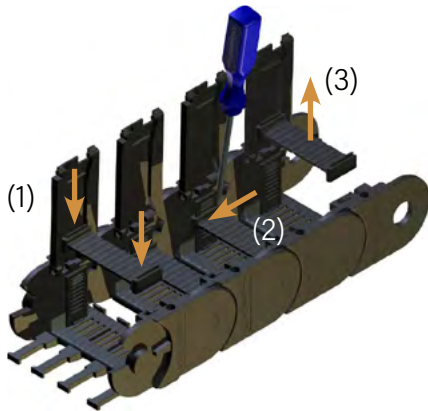

## ASSEMBLY OF HORIZONTAL DIVIDERS

The horizontal dividers (notched, telescopic and ladderstay) are horizontally slid onto the vertical dividers (PZ) (1).

With a screwdriver the locking tongue can be mounted (2) and horizontal dividers disassembled (3).

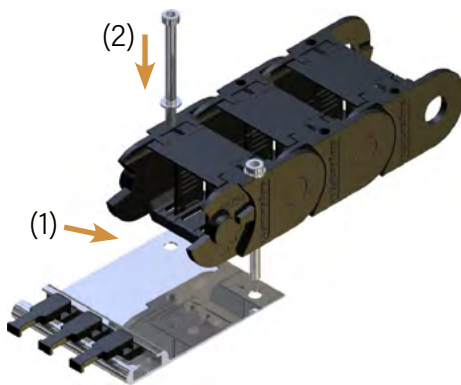

## MOUNTING THE ENERGY CHAIN AND STRAIN RELIEF

Before mounting the energy chain horn stays may be assembled which can be used to fix the lines via cable ties. For most applications variable strain relief is recommended, to mount the anchor profile with the energy chain using the integrated connector. (1), (2).

It is also possible to attach the anchor profile as a separate strain relief. The anchor profile is suitable for various strain relief components (see design guidelines).

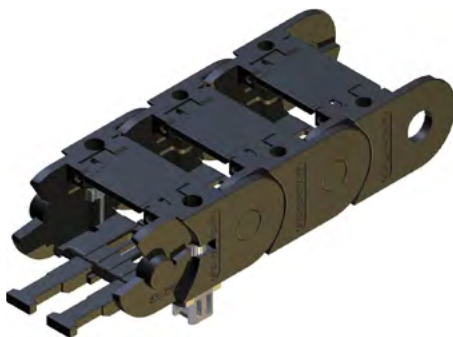

## SNAP ASSEMBLY

The energy chain may be assembled with only one click using the Snap connector.

Horn stays will be clipped at the stays as strain relief elements. After that the energy chain can be clicked in the designated position.

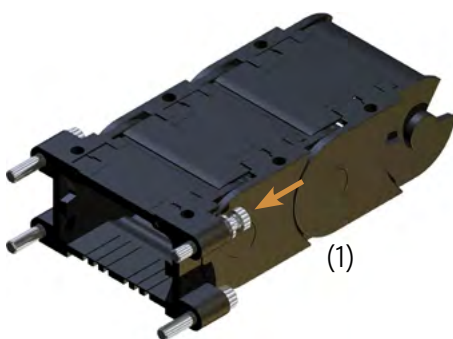

## MAINTENANCE OF THE ENERGY CHAIN

Kolibri energy chains are maintenance free. Like every mechanical system there will - depending on the ambient conditions - wear which must be observed. In case of this the energy chainspace has to be exchanged.

# PKK PLASTIC CABLE CARRIERS



## PKK FEATURES

- Mounting brackets not needed. All plastic energy chains are equipped with integrated mounting holes on each link
- Robust design
- Fast Stay assembly and disassembly.
- Extremely rigid and wear resistant.
- Easy to shorten and lengthen
- Three-dimensional chain
- Smooth motion. No "break in time" needed

## APPLICATIONS

robotics

handling

machine tools

textile industries

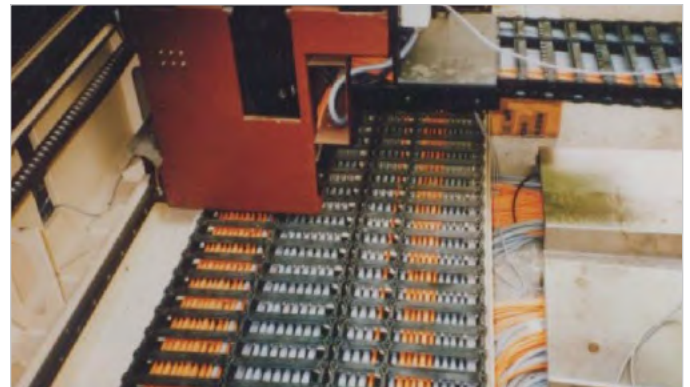

# PKK PLASTIC CABLE CARRIERS

## LOAD DIAGRAM

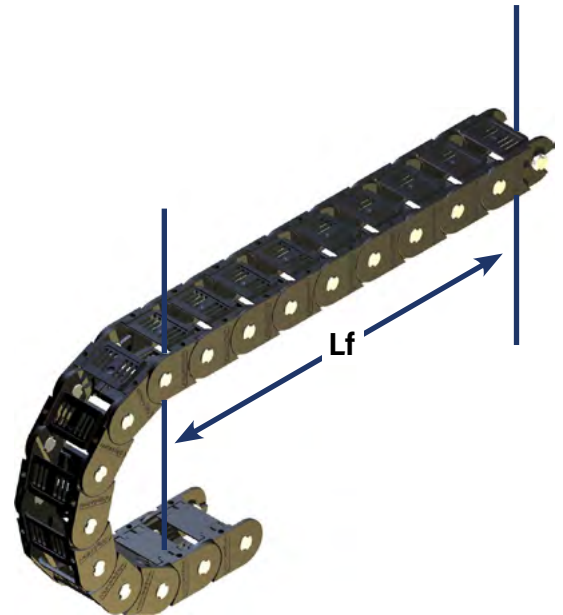
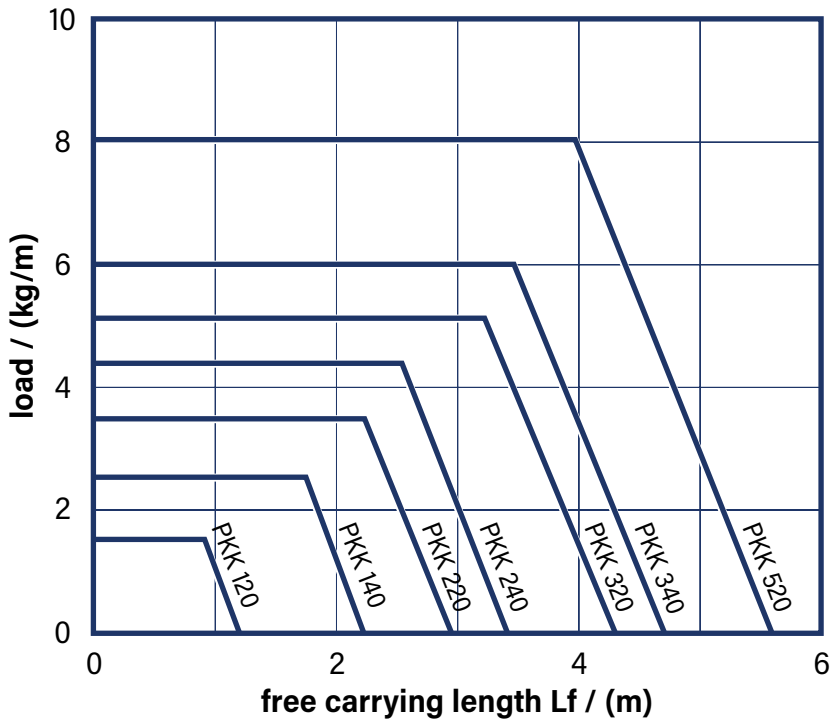

## DIMENSIONS

<b>bending radii:</b>	40 - 500 mm
<b>inner height:</b>	16 - 80 mm
<b>inner width:</b>	30 - 400 mm
<b>weight:</b>	0.6 - 3.4 kg/m

## TEMPERATURE

Long term temperature limits are between  $-20^{\circ}\text{C}$  and  $100^{\circ}\text{C}$ .

## SPECIAL VARIANTS

<b>ELTOLA:</b>	silent running
<b>ALLROUND</b>	all movements
<b>ATEX:</b>	EX-protection
<b>ESD:</b>	antistatic
<b>V-0:</b>	self extinguishing

## TRAVEL DISTANCE

The maximum range of travel is determined by the arrangement and the additional weight (line weight). At normal arrangement the maximum travel is double free carrying length. Support rollers or similar constructive steps can increase this value.

Travel distances up to 100 meters are possible (see chapter on design guidelines).

## TRAVEL SPEED

There are no limits for the travel speed in general. But with gliding arrangements application specific influences have to be taken into account.

## ACCELERATION

There are no limits for the accelerations, in general. Limits may occur through the tensile stresses at high line weights.

# PKK PLASTIC CABLE CARRIERS | DIMENSIONS

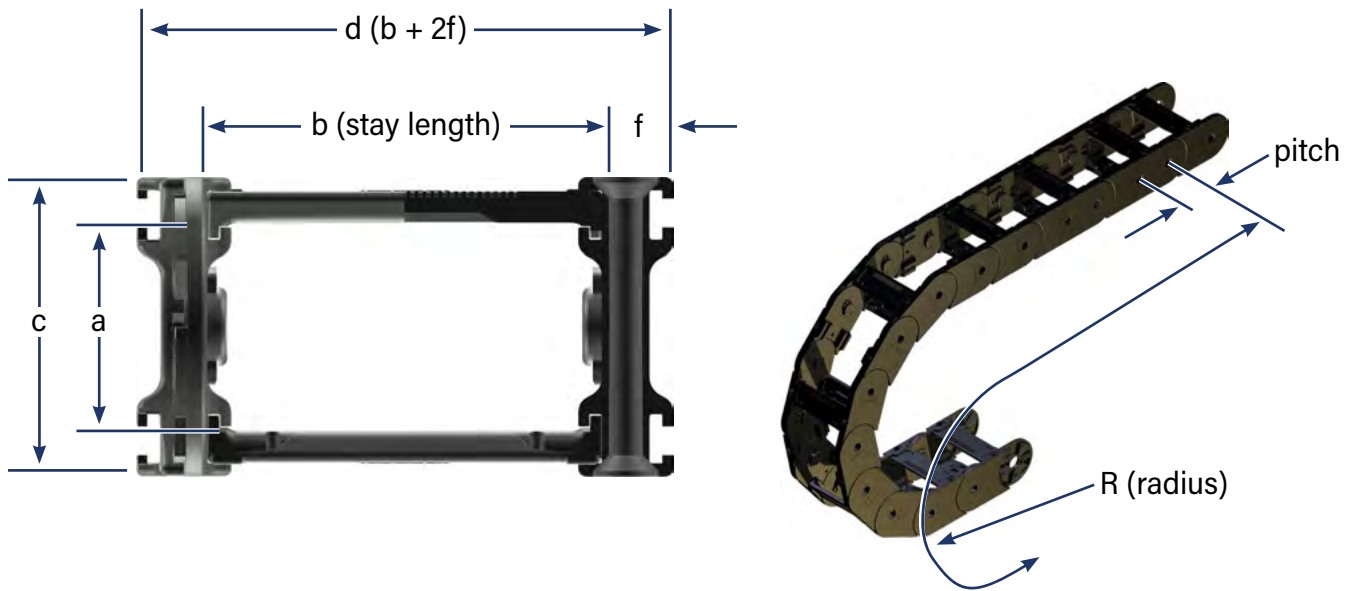

## DIMENSIONS

PKK type	pitch	dimensions			weight kg/m
		a	c	f	
120, 121, 123, 125	35	16	25	11	.60
110, 111, 113, 115	35	16	25	8	.60
140, 141, 143	54	30	40	9	1.03
220, 221, 223, 225, 228	65	34	50	15	1.50
210, 211, 213, 215	65	34	50	10	1.40
240, 241, 243, 245	65	44	60	10	1.70
320, 321, 323, 325, 328	90	51	75	18	2.50
310, 311, 313, 315	90	51	75	12	2.50
340, 341, 343, 345	90	61	85	15	2.70
520, 521, 523, 525, 528	115	80	104	14	3.40
510, 511, 513, 515	115	80	104	14	3.20

1) The usable interior width is stay length - 2e minus the width of the used PZ

2) First latching the PZ (latching all 2mm); PKK 215,225,245, 315, 325, 345 i=22;

3) Dimension does not apply to the closed type

4) PKK 115 and 125 from R50, 215 and 225 from R100, 245, 315 and 325 from R150, 345, 525 and 515 from R200

5) The inner radius covers (ASI) of length 200 mm of the PKK 215, 225, 245 and 300 mm and 200 mm of the PKK 315, 325, 345 are designed with a pivot on one side.

6) PKK 228 from R100, PKK 328 from R150, PKK 528 from R200

\* Additional stays available

+ Sliders available

## RADIUS

PKK type	R (radius) radii available for each type
120, 121, 123, 125 <sup>4)</sup>	40, 50, 60, 75
110, 111, 113, 115 <sup>4)</sup>	40, 50, 60, 75
140, 141, 143	50, 60, 80, 100, 150, 200
220, 221, 223, 225 <sup>4)</sup> , 228 <sup>6)</sup>	75, 100, 150, 200, 250, 300
210, 211, 213, 215 <sup>4)</sup>	65, 75, 100, 100, 125, 150, 200, 250, 300
240, 241, 243, 245 <sup>4)</sup>	75, 100, 120, 150, 200, 250, 300
320, 321, 323, 325 <sup>4)</sup> , 328 <sup>6)</sup>	100, 150, 200, 250, 300, 400
310, 311, 313, 315 <sup>4)</sup>	100, 130, 150, 200, 250, 300, 400
340, 341, 343, 345 <sup>4)</sup>	100, 150, 200, 250, 300, 400
520, 521, 523, 525 <sup>4)</sup> , 528 <sup>6)</sup>	150, 200, 250, 300, 400, 500
510, 511, 513, 515 <sup>4)</sup>	150, 200, 250, 300, 400, 500



\* Additional stays



+ Sliders

## STAY LENGTH

PKK type	b stay lengths available for each type
120, 110, 111, 113*, 121, 123*	30, 50, 60, 70, 80, 90, 100, 110, 120
115, 125	50, 100
140, 141, 143*	30, 50, 60, 70, 80, 90, 100, 110, 120
220, 210, 211, 213*, 221, 223*, 228+	50, 60, 70, 80, 90, 100, 110, 120, 130, 150, 170, 200, 220
215, 225 <sup>5)</sup> +	50, 100, 150, 200
240, 241, 243*	50, 60, 70, 80, 90, 100, 110, 120, 130, 150, 170, 200, 220
245 <sup>5)</sup>	50, 100, 150, 200
320, 310, 311, 313*, 321, 323*, 328+	50, 60, 70, 80, 90, 10, 120, 130, 150, 170, 180, 200, 230, 50, 270, 300, 330, 400
315, 325 <sup>5)</sup> +	100, 150, 200, 300
340, 341, 343*	50, 60, 70, 80, 90, 10, 120, 130, 150, 170, 180, 200, 230, 50, 270, 300, 330, 400
345 <sup>5)</sup>	100, 150, 200, 300
520, 510, 511, 513*, 521, 523*, 528+	50, 60, 70, 80, 90, 10, 120, 130, 150, 170, 180, 200, 230, 50, 270, 300, 330, 400
515, 525	150, 200

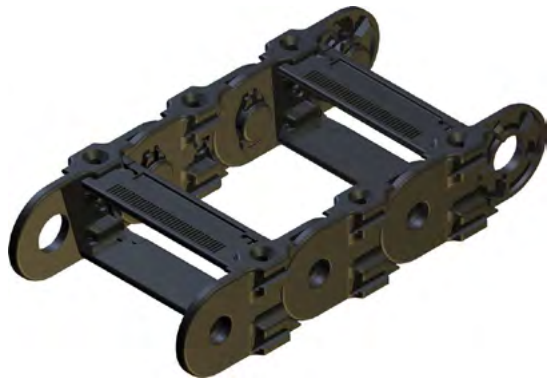

### **PKK 120, 220, 320, 520**

The standard version has a stay in every second link. With additional link bands and stays the chains can be extended as multiband chains. The integrated connector makes each link in the chain to a mounting link.

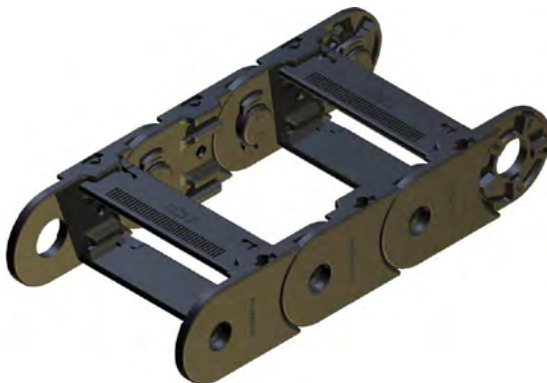

### **PKK 110, 140, 210, 240, 310, 340, 510**

The smooth designed PKK corresponds to the standard version, but has no exterior T-slot. These types provide a very good visual effect and a smaller width through the flat outside surfaces (also see PKK 215, PKK 245). The PKK 240 and 340 offer larger cross sections due to the increased link height.

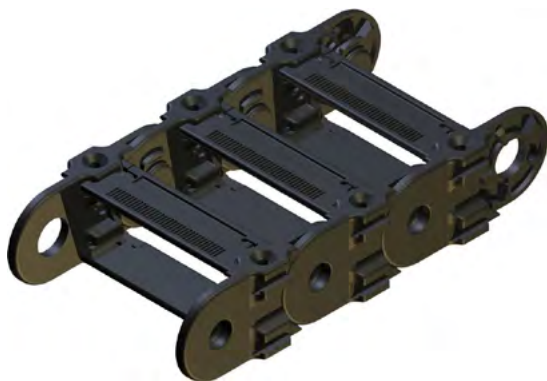

### **PKK 121, 221, 321, 521**

The types PKK -21 are manufactured with a stay in each link. The additional stays increase the lateral stability and optimize guiding of particularly smaller cable diameter.

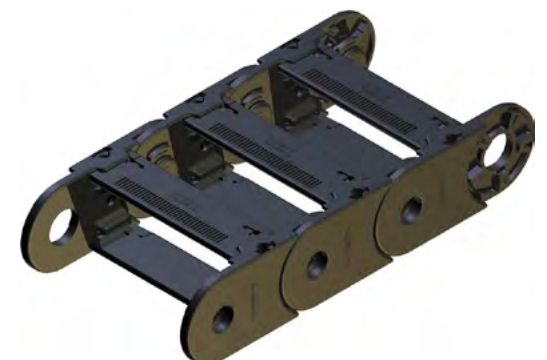

### **PKK 111, 141, 211, 241, 311, 341, 511**

These are the smooth designs with a stay in each link to increase lateral stability and optimize guiding of particularly small cables. PKK 241 and PKK 341 have a higher capacity due to their increased link height.



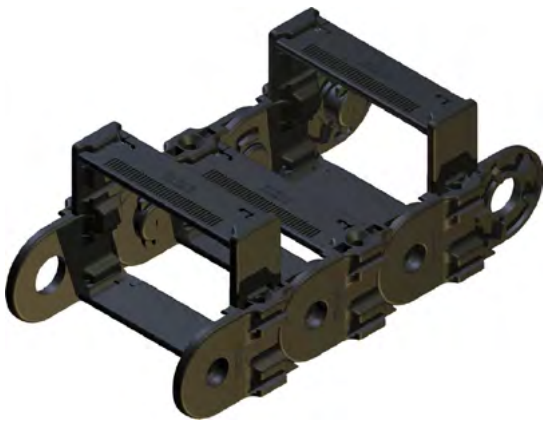

## **PKK 113, 123, 143, 213, 223, 243, 313, 323, 343, 513, 523**

The PKK with extension stays in the inner radius. Suitable for low speeds these stays create additional space. The extension stays can be arranged in the outer radius or in other combinations as per optional drawing. The extension stays are available in two lengths.

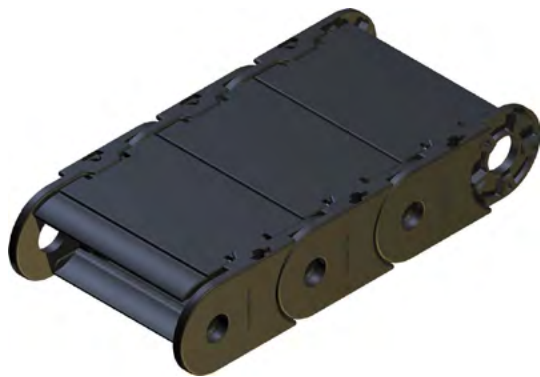

## **PKK 125, 225, 325, 525**

The closed designs offer optimum protection of the lines against chips or against UV radiation. The covers can be opened in the inner or outer radius. The closed types may also be subsequently created from the standard version.

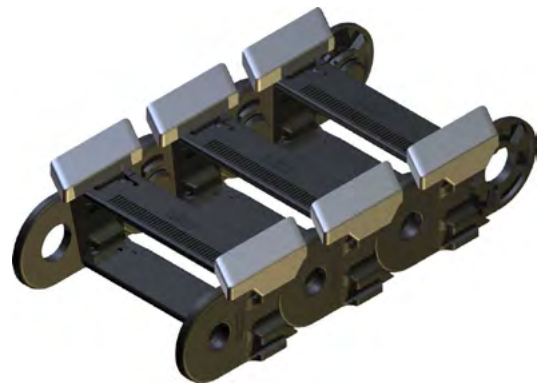

## **PKK 228, 328, 528**

The PKK 128, 228 and 328 with sliders are designed for gliding arrangements (long travel distances) and are fitted with stays in each link. The sliders are mounted in the inner radius of the energy chain and have a very low coefficient of friction ( $\mu = 0.2$  to  $0.25$ ). The sliders can also be installed afterwards.

At low stroke rates and low speeds ( $<1\text{m} / \text{s}$ ) sliders are not necessary. The smallest radius of each dimension of the PKK is not suitable for sliders.



## **MULTIBAND ENERGY CHAINS**

Multiband energy chains can be created by attaching additional link bands. These are assembled through stays at standard energy chains (see assembly, except PKK with smooth exteriors).

## PKK PLASTIC CABLE CARRIERS | SIZES



**PKK 120**

height 25

inner height 16



**PKK 140**

height 40

inner height 30



**PKK 220**

height 50

inner height 34

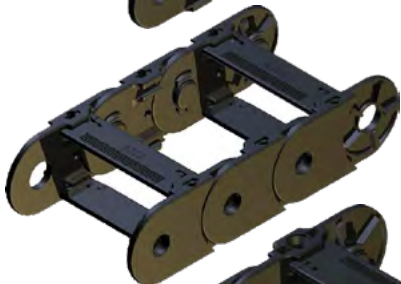

**PKK 240**

height 60

inner height 44

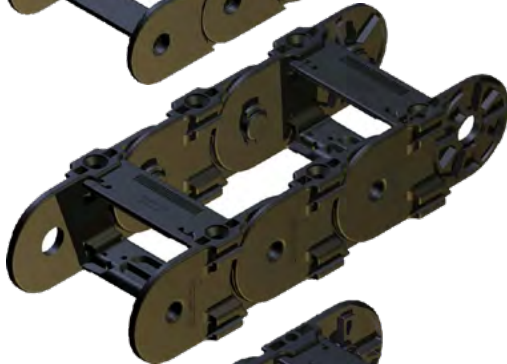

**PKK 320**

height 75

inner height 51

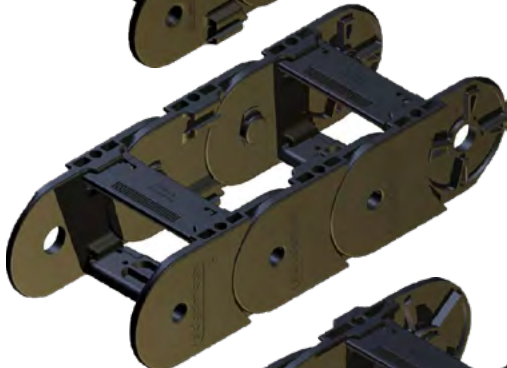

**PKK 340**

height 85

inner height 61

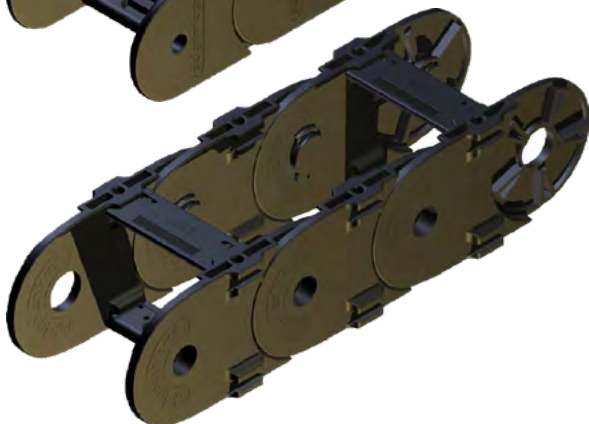

**PKK 520**

height 104

inner height 80

# PKK PLASTIC CABLE CARRIERS | PARTS

- 1 PKK 220 link
- 2 PKK 210 link
- 3 SD / Z (universal flange connector pivot)
- 4 SD / B (universal flange connector drilling)
- 5 PKK 220 connector link short (drilling)
- 6 PKK 220 connector link short (pivot)
- 8 spreader
- 9 22 stay 100
- 10 22 ASI 100 (inner cover)
- 11 22 ASA 100 (outer cover)
- 12 cover holder
- 13, 13a PZ (plastic divider)
- 14 PT 55 / PT 75 (telescopic horizontal divider)
- 15 extension stay long
- 16 extension stay short
- 17 slider R100
- 18 damping element
- 19 band holder
- 20 ladder stay
- 23 horn stay 220
- 24 PZ fork stay
- 25 PZ fork stay short
- 26 Snap (optional)  
(Pos.3,4: Art.2143, 2142)

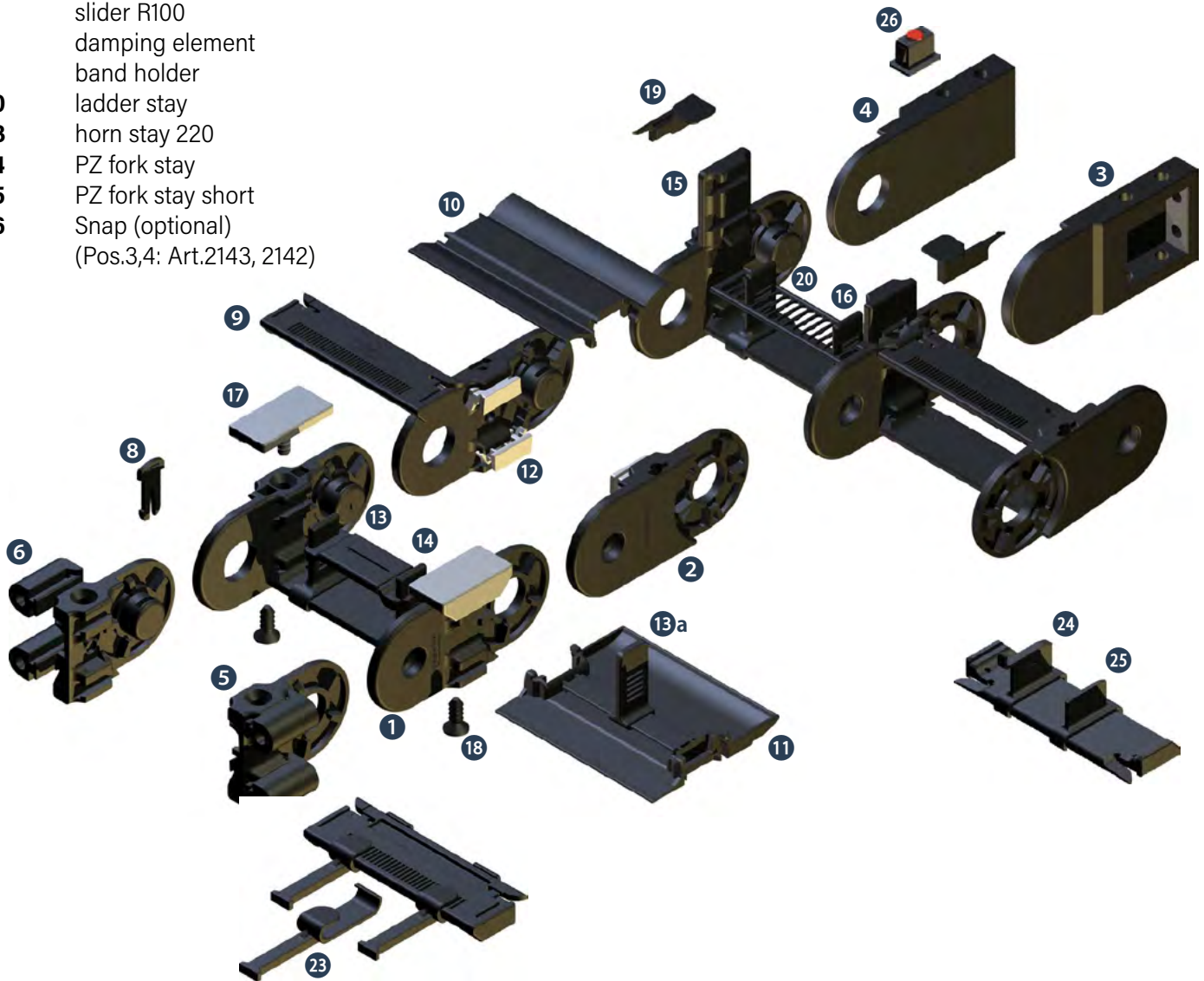

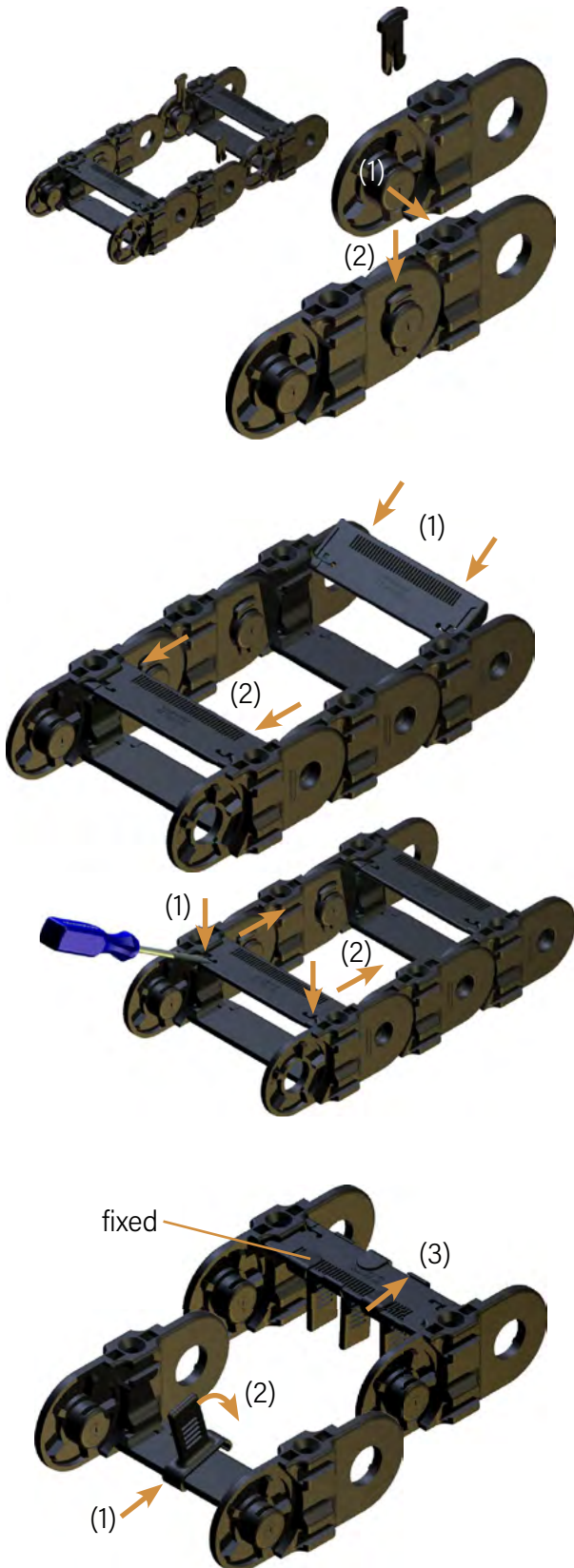

## PACKAGING

Energy chains are supplied in transport friendly packaging. When removing the packaging and during removal of the energy chain or parts of it, ensure that the energy chains are free of torsion and tension, to avoid mechanical damage.

## LENGTHENING AND SHORTENING

Lengthening of the energy chain is done by fitting of energy chain pieces or links (1) and lock with spreader (2). To shorten the spreader is disengaged and removed, then the piece of chain removed. Alternatively first link strands may be mounted and then stays assembled.

For the PKK the opposite link strands are rotated by 180 ° and arranged with the pivot on the inner chain.

## STAY ASSEMBLY

The stays with the locking tabs are put in the T-guide of the link (1) and push until it clicks into the guides (2).

The stays can be positioned initially in the T-guide and will be engaged in one swoop (plastic hammer or similar) in the final position.

## STAY DISASSEMBLY

The lock tongue of the stays are unlock with a screwdriver (1) and the stays pushed out with light pressure to the front of the T-slot (2). For medium and larger series (from PKK220) the stays can be unlocked with a light hit on the lock tongue (plastic hammer or similar) and then ejected.

## PLASTIC DIVIDER PZ (VERTICAL)

The PZ will be placed in the designated position on the stay (1) and engaged (2). The PZ can be mounted fixed or movable.

The dismantling is done by unlocking (3) and removal of the PZ.

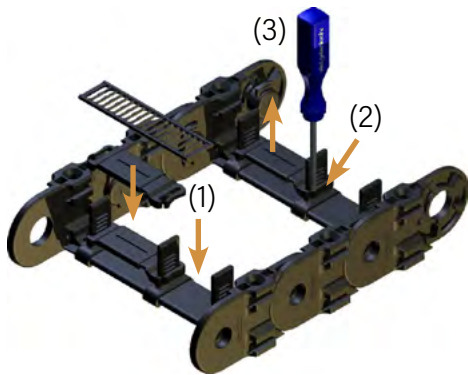

### TELESCOPIC DIVIDER AND LADDER DIVIDER

The telescopic horizontal divider and ladder stay horizontally pushed onto the plastic divider (PZ) and engaged in the designated height (1). The disassembly is done with a screwdriver through pull (2) and removal (3).



### PZ FORK STAYS

The fork stays allow in combination with an additional stay a horizontal separation and several vertical separations. Fork stays are clipped upon the stays like plastic divider PZ (p.56).

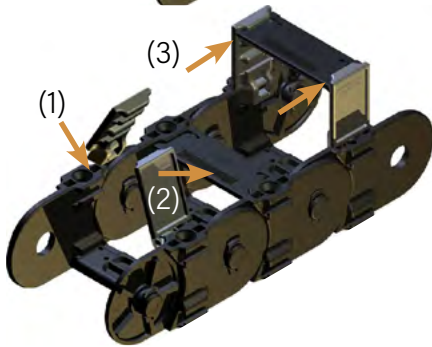

### EXTENSION STAYS

The extension stays are pushed onto the link guides (1) and pivoted until it clicks (1). Then the stays are pushed into the guides until it clicks (3).

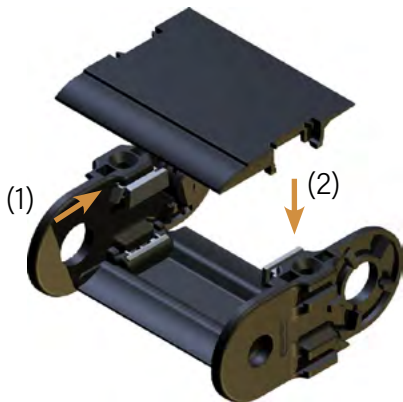

### COVERS

Before installing covers (ASA/ASI) first segment holder have to be pushed in the T-slot of the links (1). Then the covers can be plugged in (2). Covers and segment holder snap in the end position.

The covers are marked with arrows, to avoid wrong assembly direction.

Covers for the outer radius are equipped with holders for divider (PZ).



During assembly, ensure the correct overlap of the covers and that the covers are engaged on all four locking points. The inner radius covers (ASI) of length 200 mm of the PKK 215, 225, 245 and 300 mm of the PKK 315, 325, 345 are designed with a pivot on one side. The cover has to be pushed into the T-slot of the link on its pivot side (1) and can swing to close or open (2). For that the cover holder has to be unlocked (see disassembly).

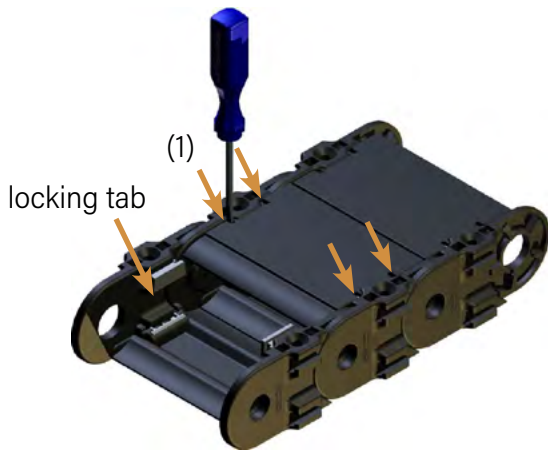

The dismantling of the covers is done by unlocking and lifting out. These are done one by one at a time with the 4 locking tongues on the segment holders using a screwdriver (1), then the cover is easy to raise. With two release tools all four locking tongues can be done at once and the cover removed.

**Attention:**

*The release tools can only be resolved if covers are dismantled (by lateral withdrawal)*

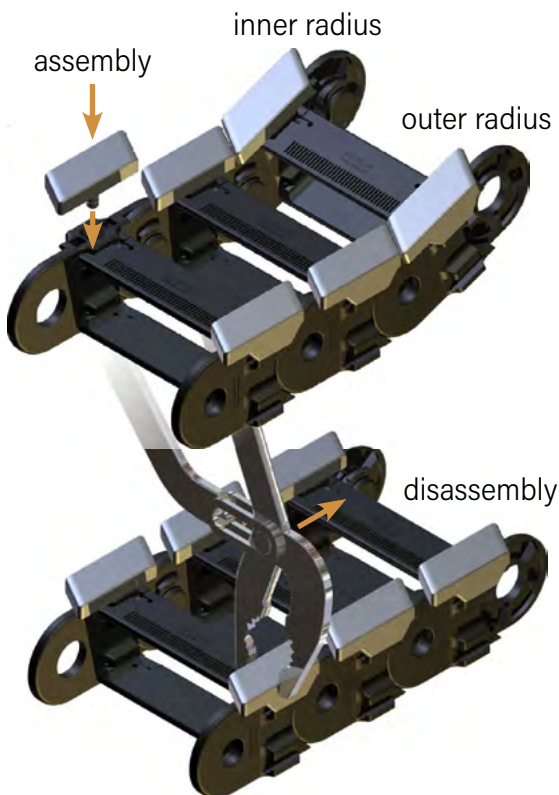

Covers with lengths 200 mm and 300 mm of the PKK 225 and 325 are equipped with a pivot on one side. These covers opening mechanism is deactivated on one side. The covers can be swiveled.

## SLIDERS

The sliders are mounted in the inner radius of the energy chain. The minimum bend radius in each PKK size can not be fitted with sliders.

During assembly of the sliders be aware of the following: The sliders must be conditioned (water content min. 1%, overnight storage in water at room temperature or 2 h at 80° C).

Heat the slider just before mounting in a water bath. Avoid impact load.

The dismantling is carried out channel lock pliers as shown and unlock slider by turning it to the outer side.

## MULTIBAND ENERGY CHAINS

Multiband energy chains can be created by attaching additional link strands. These are attached to existing energy chains by additional stays (see stay assembly).

By combining with extension stays large hoses or other additional components may be carried.

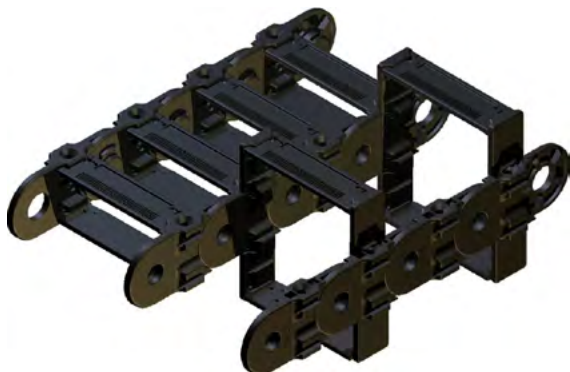

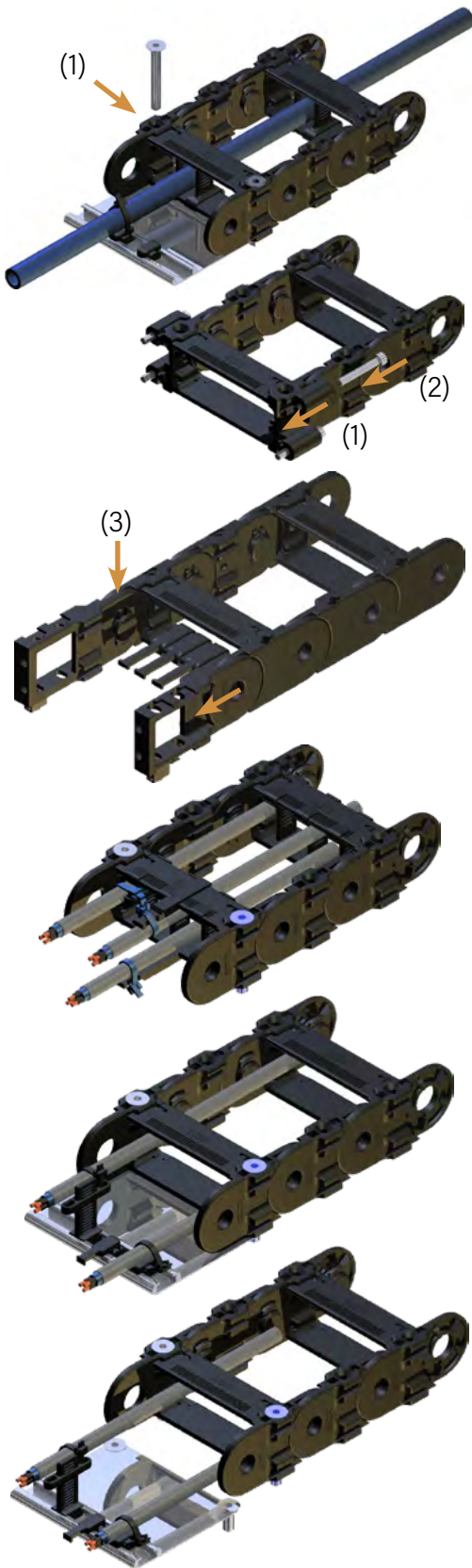

## MOUNTING THE ENERGY CHAIN

All of our plastic energy chains are equipped with the integrated connector (1). When using integrated strain relief, no additional components are needed. Provision for the combined strain relief, the anchor profile has to be screwed with the first link in the chain. Separate strain relief can be subsequently mounted.

## HEADSIDE MOUNTING

Optionally, the attachment can be made with flange connectors or universal connectors. The flange connectors are mounted in the T-slots of short connectors links until locking (1). The energy chains can be attached through four flange connectors (2).

The SD connectors are mounted like the links with the spreader (3) and provide universal connection options, as an example with Snap for fast and tool-less assembly.

## STRAIN RELIEFS

With long travel distances and high speeds the lines at one end of the cable carrier, preferably on the moved driver, are attached to strain reliefs. The distance of strain relief to the bending area depends on the particulars of the line manufacturer.

## INTEGRATED STRAIN RELIEF

In this space-saving type strain reliefs are directly mounted on the vertical divider (PZ) of the first link of the energy chain.

The mounting direction of the PZ must be chosen so that tension directed on the chain can not unlock the divider. In order to avoid premature line wear caused by dynamic loads a small extra chain length is recommended.

## COMBINED STRESS RELIEF

The combined strain relief combines the advantage of sufficient distance from the strain relief to the bending line areas provided by a simple and space-saving installation of the integrated strain relief.

The anchor profile is fitted to the drilling dimensions of the energy chain (integrated connectors) and attached to this. The lateral insertion and extraction of strain relief elements is possible at any time.

## SEPARATE STRESS RELIEF

The separate strain relief is recommended for high dynamic loads and large line diameters. A sufficient distance from the strain relief to the chain is easy to implement.

# SLE STEEL CABLE CARRIERS



## SLE FEATURES

- Available in steel, stainless steel and hardened steel
- Stay distribution in many variants
- Fast Stay assembly and disassembly
- Easy to shorten and lengthen
- Shroud to protect the pivot mechanics

## APPLICATIONS

machine tools

mills

spacial machinery

wood processing industry

conveying and lifting equipment

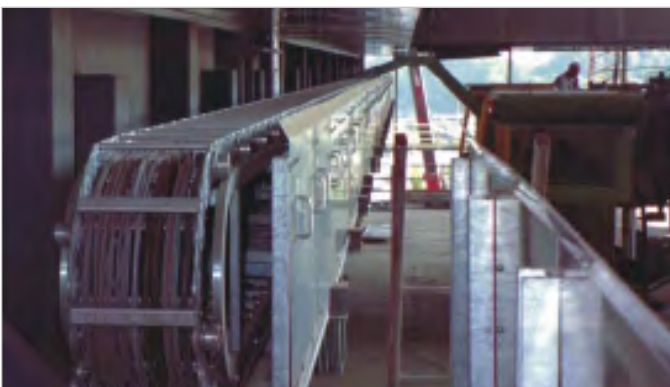
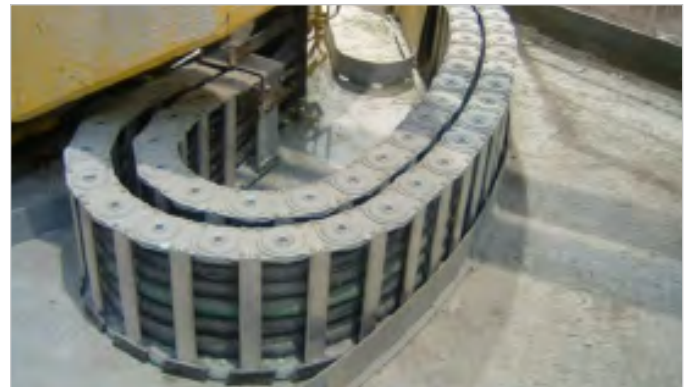



# SLE STEEL CABLE CARRIERS

## LOAD DIAGRAM

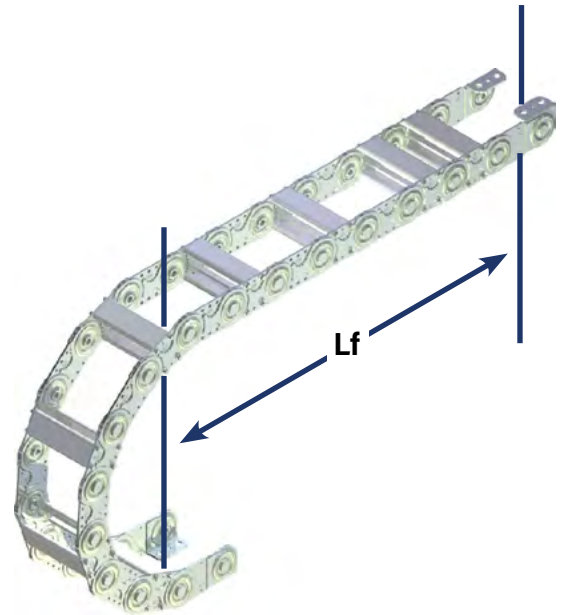
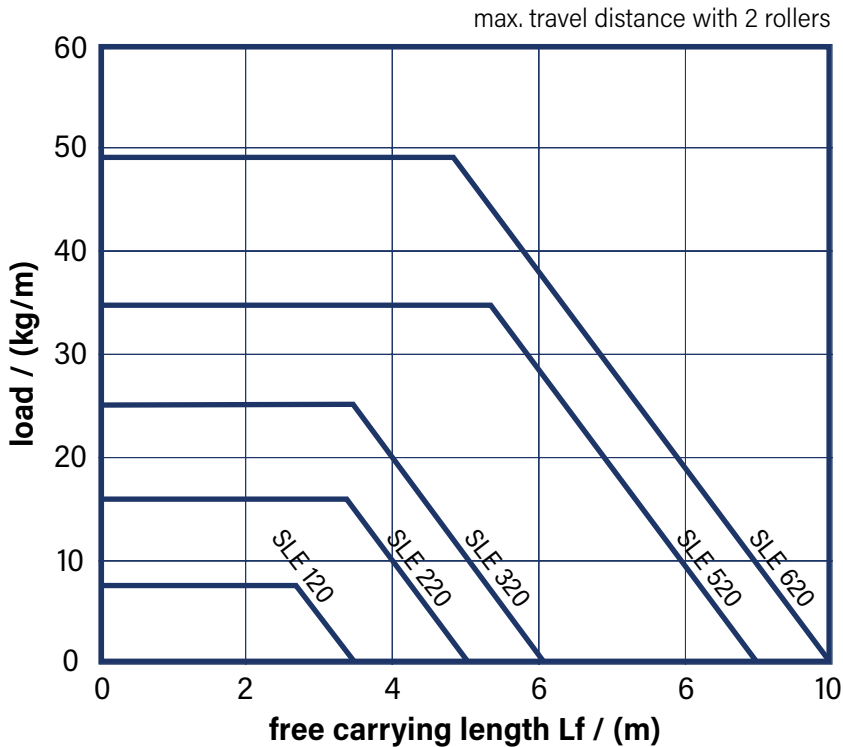

## TEMPERATURE

Long term temperature limits are between  $-20^{\circ}\text{C}$  and  $600^{\circ}\text{C}$ .  
(for stainless the limits are  $-40^{\circ}\text{C}$  and  $600^{\circ}\text{C}$ )

## TRAVEL DISTANCE

The maximum range of travel is determined by the arrangement and the additional weight (line weight). At normal arrangement the maximum travel is double the free carrying length. Support rollers or similar constructive steps can increase this value. Travel distances up to 100 meters are possible.

## TRAVEL SPEED

The standard and stainless steel designs are limited at 1 m/s.

## ACCELERATION

There are no limits for the accelerations, in general. Limits may occur through the tensile stresses at high line weights.

# SLE STEEL CABLE CARRIERS | DIMENSIONS

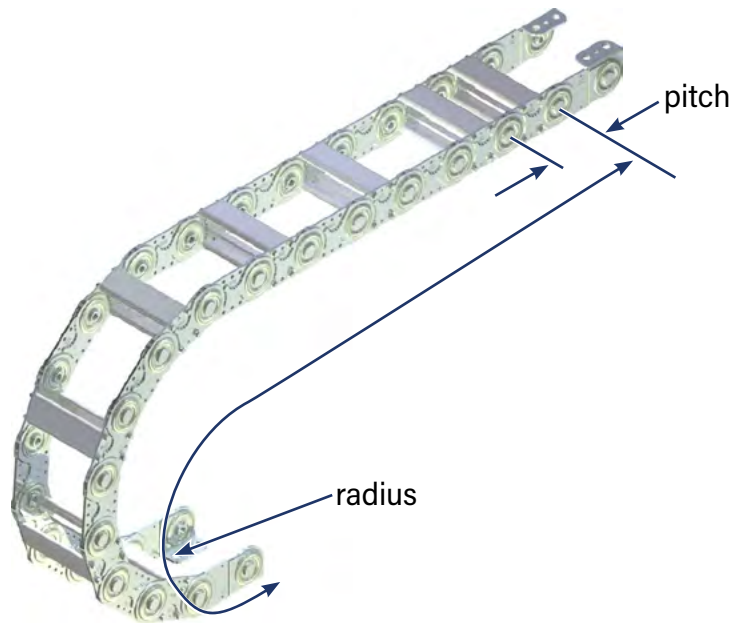
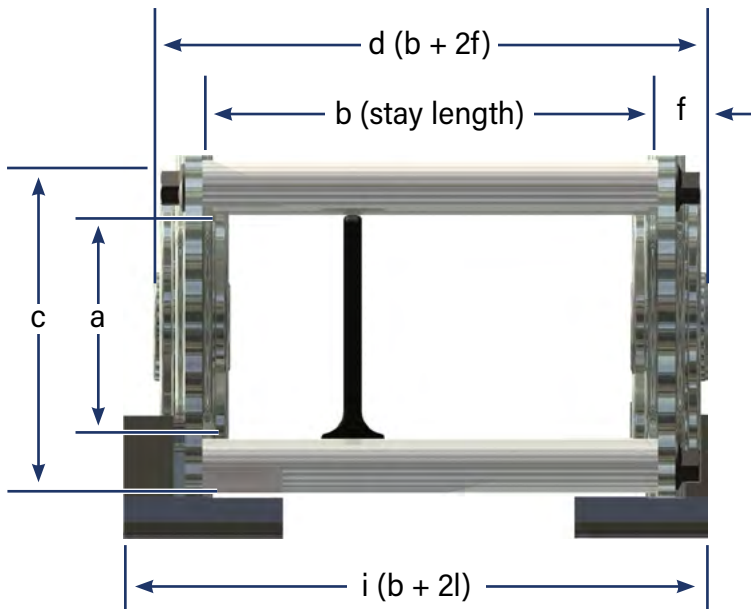

## SLE CONNECTORS

Special connectors with custom dimensions available.



**Normal:** Outer Radius

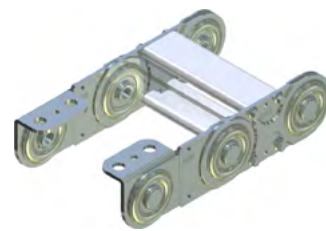

**E:** Inner Radius



**A**



**B**



**C**



**D**

## DIMENSIONS

SLE type	pitch	dimensions			weight (kg/m)
		a	c	f	
120, 121, -, 128	50	20	35	6	2.3
220, 221, 225, 228	75	31	50	8	4.3 (5.8)
320, 321, 325, 328	100	49	75	11	7.9 (9.6)
520, 521, 525, 528	125	68	100	15	15.1 (16.9)
620, 621, 625, 628	175	118	150	15	19.3 (20.9)

The weight is given for the standard type with a stay length of 100, values in brackets for closed versions.

1) b (stay length) + 2l is the width of the chain with sliders (i)

## BENDING RADIUS R [MM]

SLE type	R (radius) radii available for each type
120, 121, -, 128	60, 100, 150, 250
220, 221, 225, 228	100, 150, 200, 250, 300
320, 321, 325, 328 <sup>1)</sup>	150, 200, 250, 300, 400
520, 521, 525, 528 <sup>1)</sup>	200, 250, 300, 400, 500
620, 621, 625 <sup>2)</sup> , 628 <sup>1)</sup>	250, 300, 400, 500, 600

<sup>1)</sup> SLE 328 from R200, SLE 528 from R250, SLE 628 from R300      <sup>2)</sup> SLE 625 from R300

## STAY LENGTH & INSERTS

SLE type	stay length*	plastic inserts Ø (mm)
120, 121, -, 128	40 ... 800	-
220, 221, 225, 228	50 ... 900	10, 15, 20, 25, 30
320, 321, 325, 328 <sup>1)</sup>	60 ... 1000	10, 15, 20, 25, 30, 35, 40, 45, 50
520, 521, 525, 528 <sup>1)</sup>	70 ... 1200	10, 15, 20, 25, 30, 35, 40, 45, 50, 55, 60, 65, 70
620, 621, 625 <sup>2)</sup> , 628 <sup>1)</sup>	100 ... 1200	-

\* Stay lengths are offered in steps of 1 mm

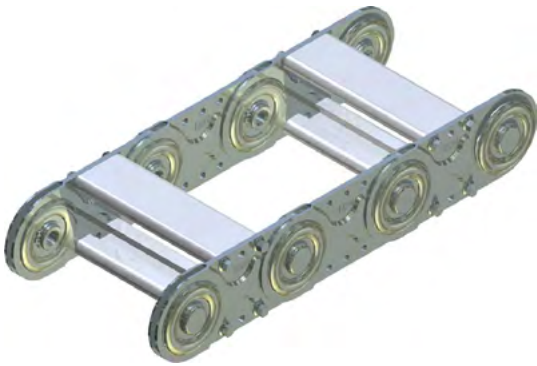

**SLE 120, 220, 320, 520, 620**

The standard type is build with stays in every second chain link. The steel link energy chains can be opened in the inner and in the outer bending radius.

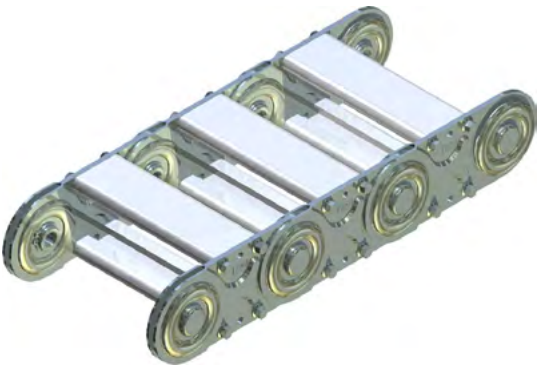

**SLE 121, 221, 321, 521, 621**

These designs are made with stays in each link. This increases the lateral stability and improves the guiding particularly of smaller diameter lines.



**SLE 225, 325, 525, 625**

The closed types offer optimum protection of the lines against dust and cuts or other environmental influences. At higher temperatures the covers Silver Star provide excellent protection. The closed types also may be built to replace the standard version stay.

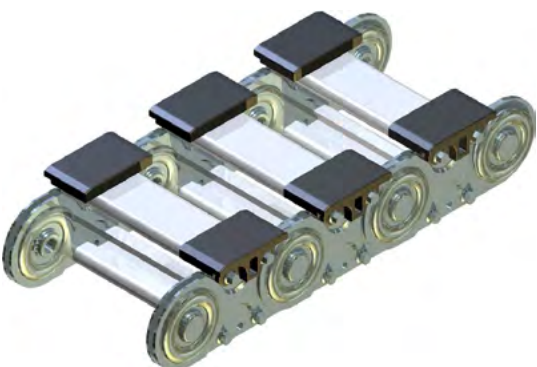

**SLE 128, 228, 328, 528, 628**

These types are suitable for long travel, the upper strand slides on the lower strand. For greater stability these energy chains are build with stays in each link. The energy chains are fitted with sliders, which have a very low coefficient of friction ( $\mu = 0.2$  to  $0.25$ ). After reaching the wear limit the slider can be renewed and the energy chain will continue.

Compared to standard chains, the SLE series is characterized by the fact that the sturdy aluminum profile can be steplessly adapted to the requirements. Stay lengths of up to 1500 mm can be provided. The subdivision of the interior satisfies every requirement and guarantees optimized cable protection, even at very high accelerations and travel speeds. For extreme applications, the variants SLA, SLS and SLE should be preferred, since these offer optimized cable guiding. In the case of high speed and acceleration a multi-layer arrangement of the cable should be avoided.



## SLA

The SLA (SLE with aluminum T-profile or aluminum slot profile) is a highly customized and robust energy chain, which is chosen primarily for larger dimensions. The stays are milled in accordance with the requirements of the user with individual hole patterns.

## SLE

The SLE (SLE with plastic inserts or plastic slot-profile) ensures at high speeds a perfect guide and almost excludes errors during installation of the lines. With this design the hole pattern of the stays can be adjusted accurately to the needs of the lines. Plastic inserts are available in a 5 mm grid. The plastic slot-profile can be ordered to suit special requirements.

## SLS

For limited installation space, the SLS (SLE with foam slot profile) are used. Again, the optimal guiding of the lines at high speeds and acceleration is ensured. Well known automotive manufacturers have used this type for years with the best experiences. All lines lie in the neutral axis of the energy chain.

## SLP

For space reasons, the SLP (SLE with plastic divider PZ and others) can be selected. This inexpensive design allows the guiding of large amounts of cable. The highly variable distribution possibility through small steps of (3mm) in height, plus the Telescopic divider (PT) allows maximum space for all needs, even when changes in cable diameters are required.

## SLR

The SLR (SLE with a pipe or roll stays) is manufactured only upon request. The pipe stay allows special material combinations, such as the exclusion of aluminum or the use of stainless steel and brass. The roll bar has advantages particularly for heavy lines with high friction and wear in terms of durability of the cables and hoses: Relative movements on the energy chain are compensated by the rolling motion of the stays.



## SLE 120

**height** 35  
**inner height** 20

**width** 52 ... 812  
**inner width** 32 ... 792  
**stay length** 40 ... 800



## SLE 220

**height** 50  
**inner height** 31

**width** 66 ... 916  
**inner width** 38 ... 888  
**stay length** 50 ... 900

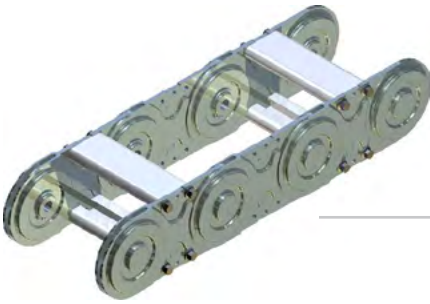

## SLE 320

**height** 75  
**inner height** 49

**width** 80 ... 1020  
**inner width** 50 ... 990  
**stay length** 60 ... 1000

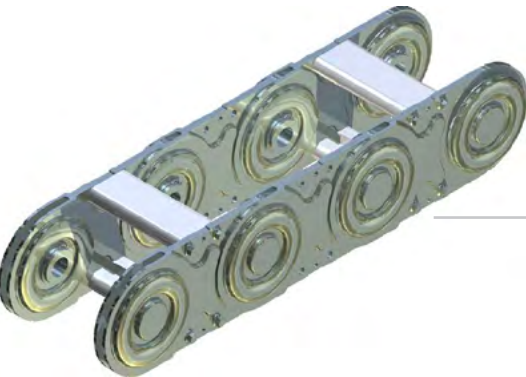

## SLE 520

**height** 100  
**inner height** 68

**width** 98 ... 1028  
**inner width** 54 ... 1184  
**stay length** 70 ... 1500

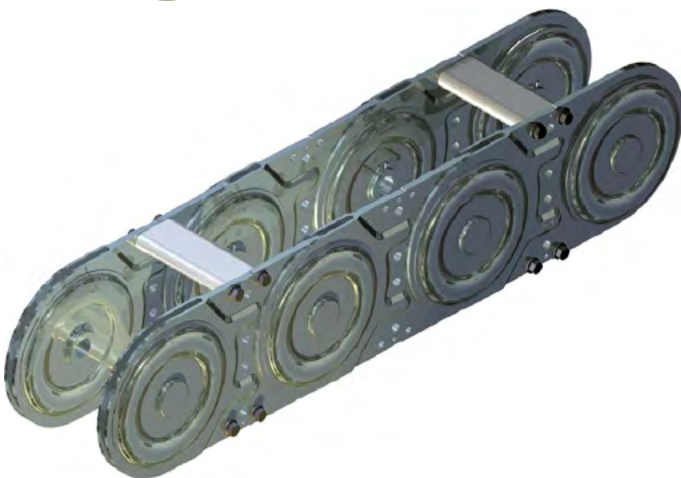

## SLE 620

**height** 150  
**inner height** 118

**width** 128 ... 1228  
**inner width** 84 ... 1184  
**stay length** 100 ... 1500

# SLE | PARTS

- 1 link
- 2 connector link single
- 3 connector link double
- 4 connector angle
- 5 flange bolt
- 6 radius bolt
- 7 cover plate
- 8 retaining ring
- 9 aluminum C-profile
- 10 serrated screw
- 11 plastic (vertical) divider
- 12 outer cover
- 13 distance filler

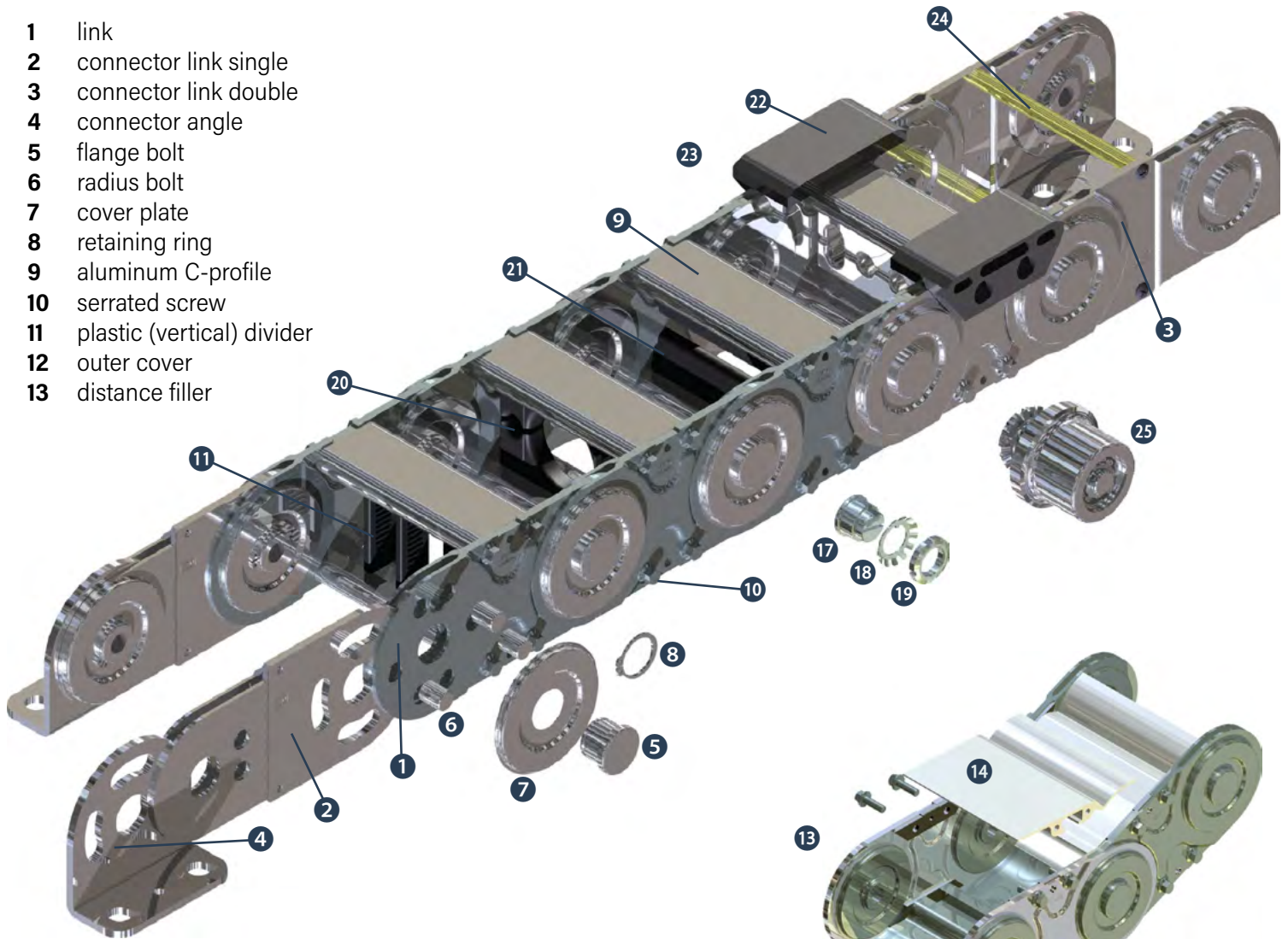

- 14 inner cover
- 15 band holder
- 16 band (steel / stainless steel)
- 17 threaded bolt
- 18 lock washer
- 19 locknut
- 20 plastic inserts
- 21 foam
- 22 slider
- 23 aluminum-T-profile
- 24 pipe stay
- 25 flange rollers

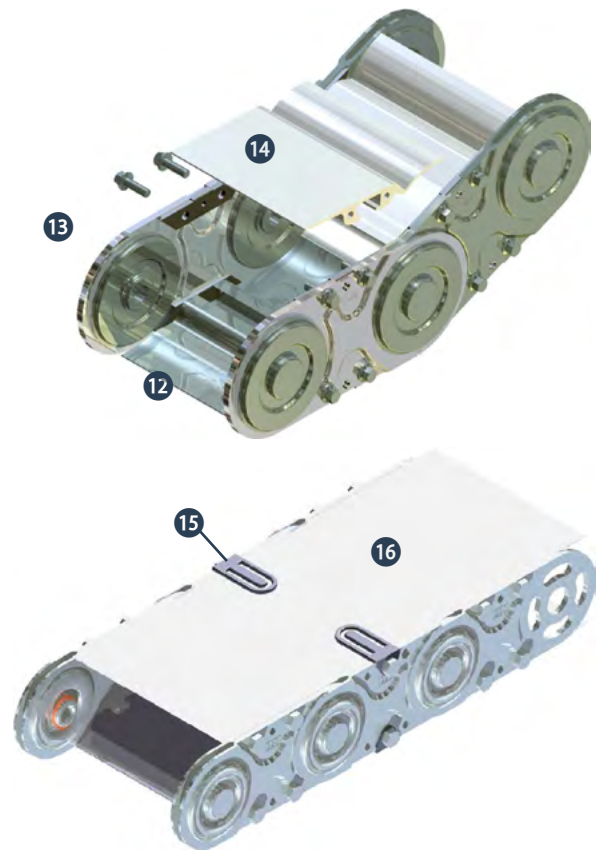

The use of steel chains with steel bands (16) is limited to energy chains with a maximum length of 6 m and stay length of 600 mm.

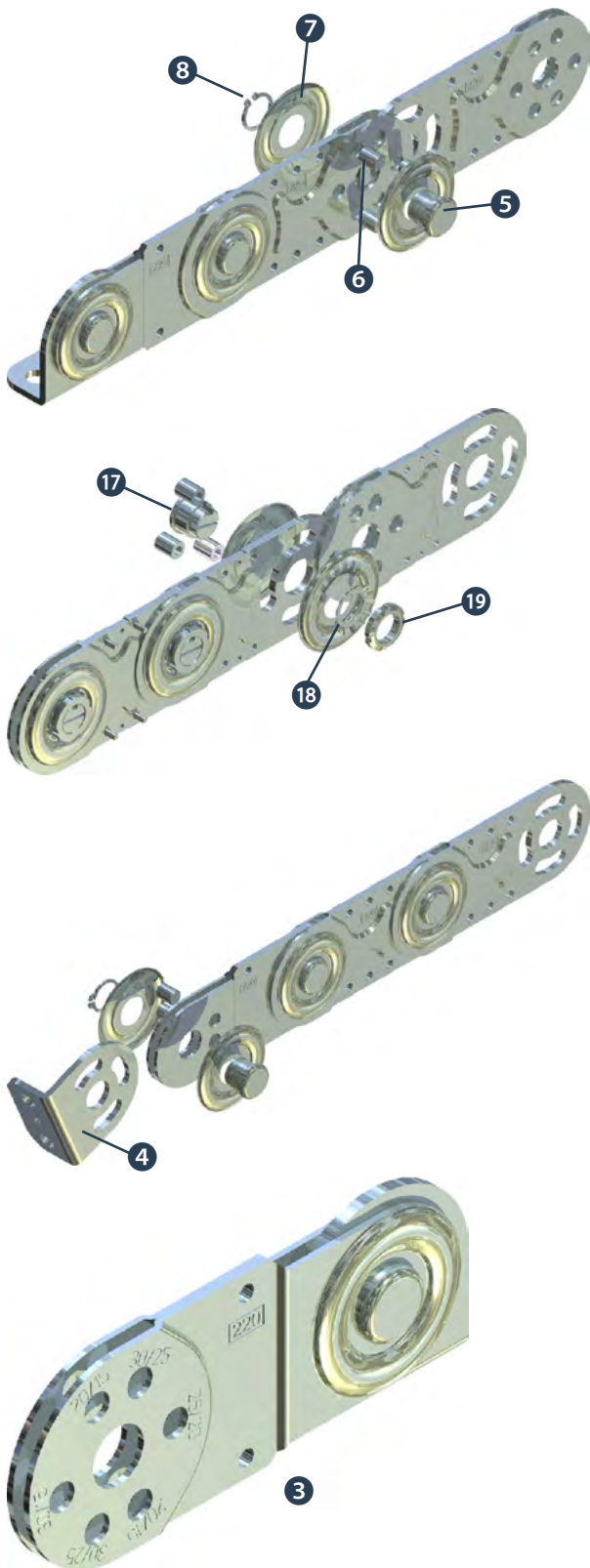

## PACKAGING

When removing the packaging and moving the energy chains or parts of them, ensure that the energy chains are free of torsion and tension to avoid mechanical damage.

## LENGTHENING OR SHORTENING

**If energy chains are delivered in pieces, proceed with the installation as follows:**

Push the link together (1) and insert the flange bolts (5) with a shroud (7) in the chain outside. Then build the radius by inserting the radius bolts (6) (see chart for correct radius). Finally put on the inner shroud (7) and fit the retaining ring (8). Roll the energy chain to check that the radius is correct throughout its length.

Shortening in the reverse order:

Loosen the retaining rings (8), pull out the flange bolts (5), lifting the shroud (7), pull the radius bolts (6) and remove the links (1).

Energy chains with threaded bolts instead of the retaining rings (8), first unlock the locking plates (18) to solve the locknuts (19). Thereafter, the threaded bolts (17) and pins (6) can be removed and taken from the links (1).

## IMPLEMENT THE CONNECTOR ANGLE

The connector angles (4) are orientated to the outer radius and to the chain center (normal end mounted). By loosening the retaining rings (8), drag the flange bolts (5), lift off the shroud (7) and pull the radius bolts (6) the connector angles (4) can be disassembled and placed in a different position.

## BENDING RADIUS

Loosen the retaining rings (1) and lift off the shrouds (7). Implement the radius bolts (6) according to table (page 20). Then mounting the shrouds (7) and retaining Rings (1). The detachable bolts position for the different radii can be found engraved on the double connector links (3).

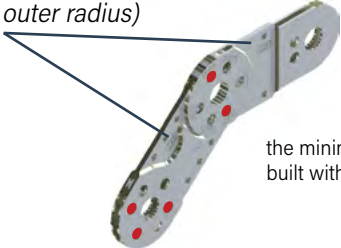
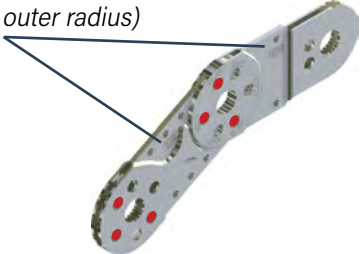
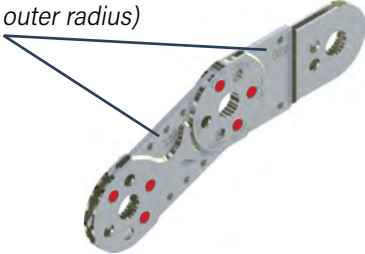
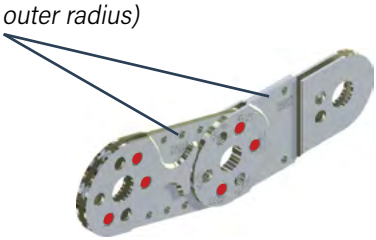
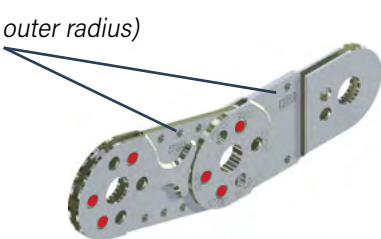

**ASSEMBLY OF RADIUS BOLTS**

SLE	120	220	320	520	620	
radius	60	100	150	200	250	<p>(marking in the outer radius)</p>  <p>the minimum radius is built with only 2 bolts</p>
radius	100	150	200	250	300	<p>(marking in the outer radius)</p> 
radius	150	200	250	300	400	<p>(marking in the outer radius)</p> 
radius	250	250	300	400	500	<p>(marking in the outer radius)</p> 
radius	-	300	400	500	600	<p>(marking in the outer radius)</p> 

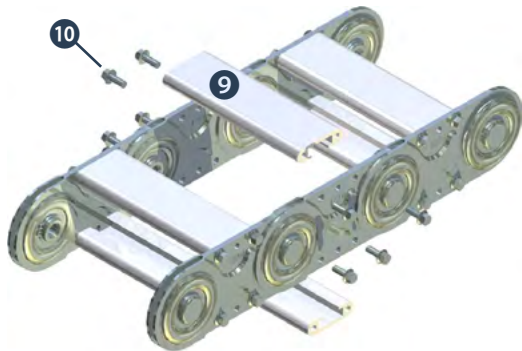

## STAY REMOVAL

The stays (9) are fastened with serrated screws (10) to the links (1). They can be removed by unscrewing the four screws (10).

Stay lengths up to 600 mm are available with quick assembly.

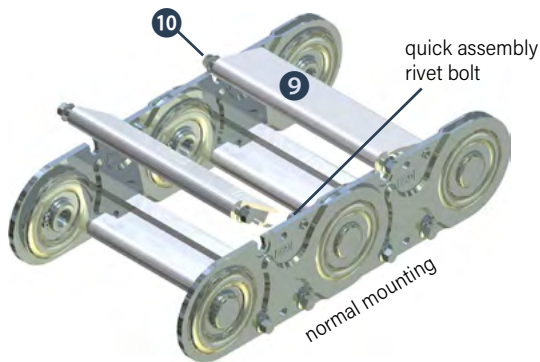

## QUICK ASSEMBLY

In quick assembly only two screws must be tightened or loosened. The stays (9) are moved with the groove on the rivet and the serrated screw (10) snapped in the recess and tightened.

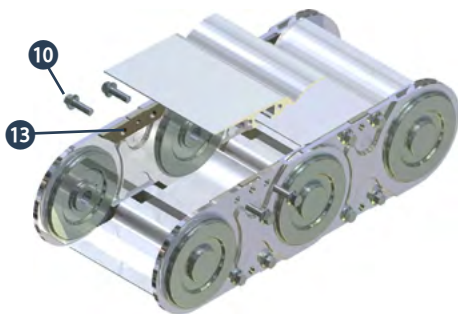

## COVER SILVER STAR

The covers of the closed version can be removed like the stays by loosening the four serrated screws (10). The spacers (13) remain on the links.

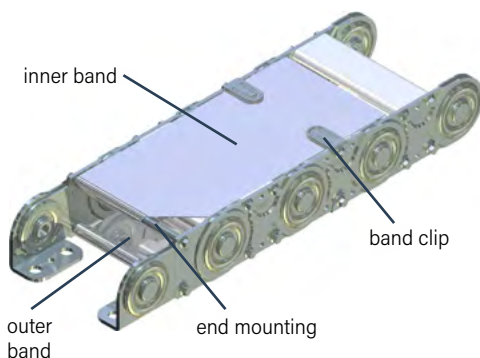

## STAINLESS STEEL BANDS

To protect the lines against external damage and pollution the chains can be equipped with steel or stainless steel bands in the inner and outer radius. The edges of the steel bands are circular smoothed to avoid injury. Stainless steel and steel bands are fastened with band holders screwed on sides and with screwed connections on each end of the chain.

## FINAL ASSEMBLY

The installation height should not fall below the level  $H = (50 \text{ plus two times bend radius plus link height})$ . The pretension of cable carrier is taken into account with the additional space of 50 mm.

First fasten fixed connection (F) and then mount the movable connection using the specified bolt size.

Compliance with the maximum free carrying length is of vital importance for the life time of the energy chain, both during the installation as well as when operational. Over travel of the energy chain can lead to damage and premature wear.

If the energy chain is provided with support elements, the assembly of these must take place before the installation of the chain in order to avoid even a short-term stress point.

An energy chain may never exceed the free carrying length without support rollers.

The height of the moved connector must be adjusted so that the connector link is moving with a maximum of 5 mm distance from the base of the supporting roller.

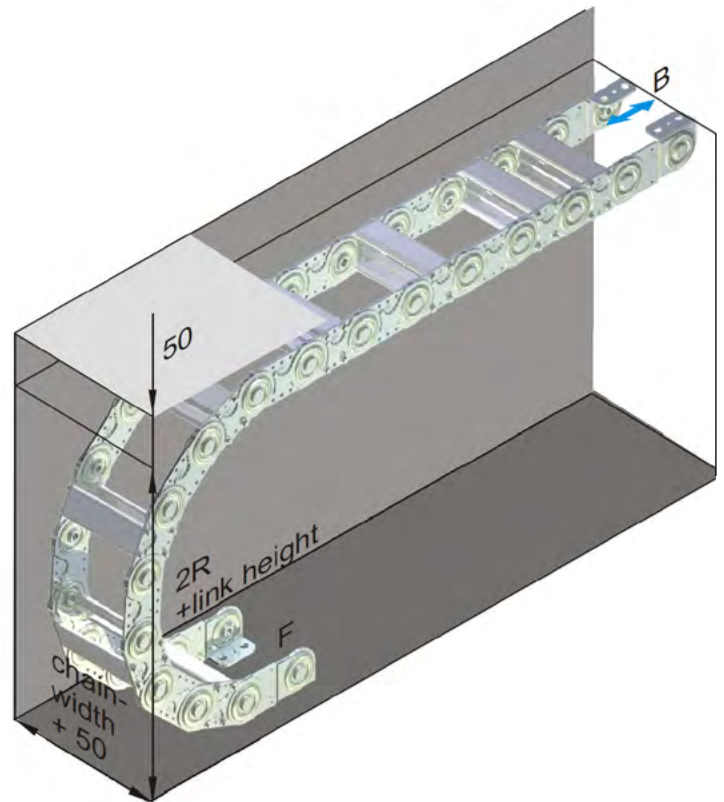

## MAINTENANCE OF THE CHAIN

Like every mechanical system this will depend on the ambient conditions so wear will occur which must be observed.

For long travels or in a circular motion, the energy chains are often equipped with sliding elements. These allow sliding of the upper part of the chain on a suitable surface (eg, slider, slider-steel, glide bar). The sliders wear depends on the application. The slider surfaces should be checked at regular intervals. With a thickness of 1-2 mm sliders have to be replaced.

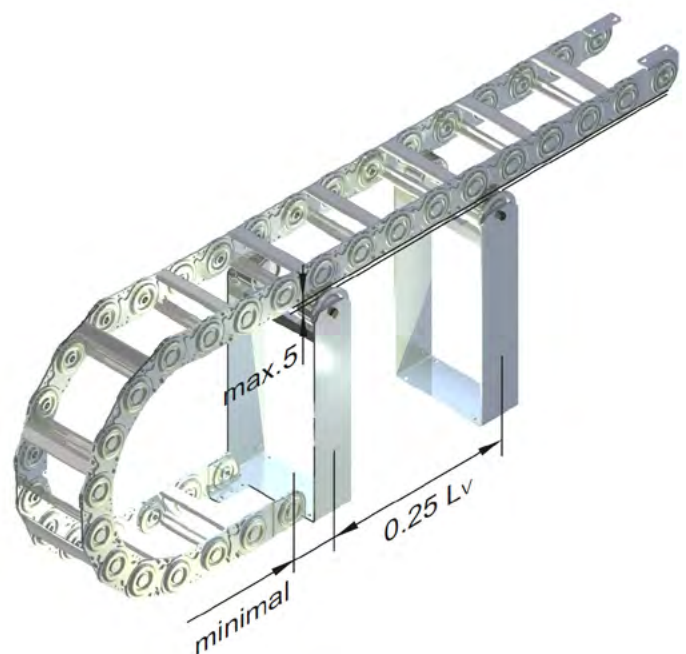

### SUPPORT BRACKETS & ROLLERS

- Support rollers are used when half of the travel exceeds the free carrying length.
- Support rollers allow four times extension of travel distance
- Roller Ø100 for all sizes
- The steel support rollers are delivered with robust high quality support frames. The height of the moved connector must be adjusted with a maximum 5mm distance from the base of the supporting roll.
- As an alternative to steel rollers (SR), plastic support rollers (PR) for plastic chains are available.

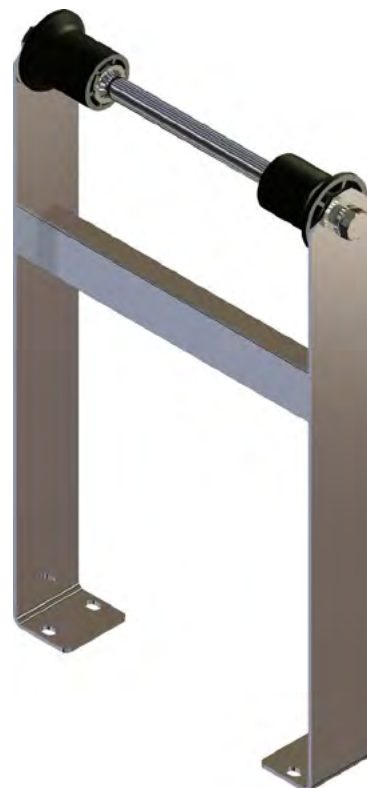
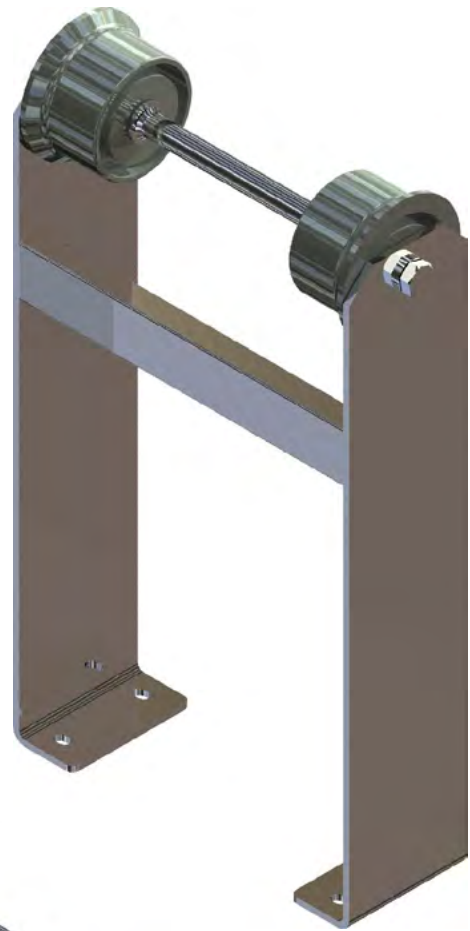

## FLANGE ROLLERS

The flange rollers are used for very long chains in combination with a support railing with supporting rollers and support frames



## GUIDE ROLLERS FOR STEEL CHAINS

Guide rollers are used for steel chains in arrangement u (moving end downside). In this case provide a trough or a corresponding support rail.

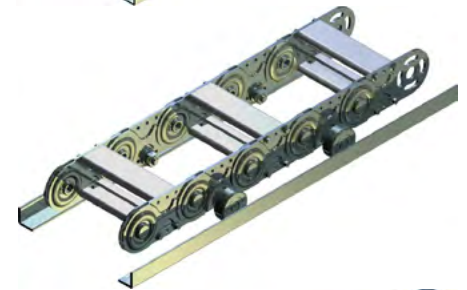

## GLIDING DISC FOR STEEL CHAINS

For the SLE in arrangement w (lying horizontally on the side) for the longest travel distance or in arrangement k (circular) gliding discs are used. The gliding discs are made of high quality, highly abrasion-resistant materials. In both arrangements a guide is necessary.



## SHELF TROUGHES FOR STEEL CHAINS

Shelf troughs consist of two standard angular channels that are welded together from 3m lengths. Shelf troughs will be used if a smooth and precise guidance of steel chains is necessary.



## SUPPORT CARRIAGE FOR STEEL CHAINS

Steel chains with support carriage are used for long travel distances and very high additional weights in a counterchain arrangement. With side-mounted guide rollers the energy chains are supported on the support carriage.

**Technical Features:** No push - just pull-tension, large travel distances, extreme additional loads, smooth running, long life.

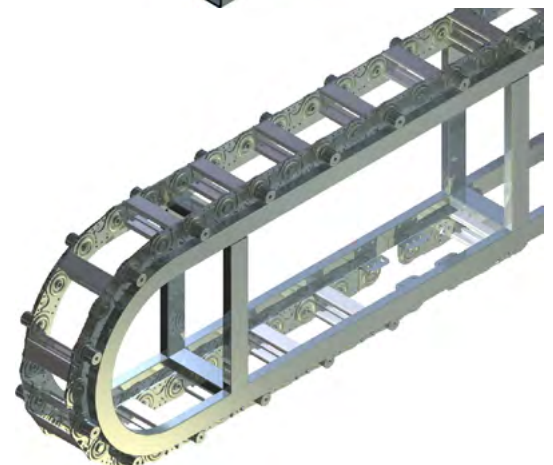

# STABIFLEX CABLE CARRIERS

STABIFLEX cable conduits are moving cable carriers which have proved successful in a wide range of applications in machine tools and machining centers. The main feature of this closed cable carrier is that through the fitting of a steel band to one of the four sides the flexible conduit can only bend in the one direction where the steel band is situated. In all other directions of movement the conduit remains stable.

STABIFLEX cable conduits are resistant against all coolants and lubricants normally used in the machine tool industry.

Two qualities are available depending on the traverse speed:

## QUALITY G

Featuring a steel band fixed with special glue for speeds of  $v \leq 50$  m/min.

## QUALITY K

Featuring a synthetic band fixed with special glue for speeds of  $v \geq 50$  m/min.

If no traverse speed is indicated, we automatically choose the G quality.

- To obtain the shortest possible length, it is recommended to have the fixed connection at the midpoint of the stroke.
- When choosing the required type of STABIFLEX, an allowance of at least 10% per cable should be considered.
- Made of zinc plated sheet steel.
- To determine the bending radius (KR), multiply the outer diameter of the cables to be installed by a factor of 8 to 10. However, the minimum bending radius indicated by the cable manufacturers is the main criterion.
- Mounting flanges are welded on both ends of the cable conduit.
- In accordance with safety regulations, electrical continuity is maintained between the flanges and the metal conduit. The cables are loosely guided in the STABIFLEX and fastened at the moving and fixed end.
- To ensure long-term functioning, it is necessary to guide the STABIFLEX in support angles or in a channel the length of which should be approx. 1/2 stroke.
- Max. length of the individual types of Stabiflex is 6.5 m, longer lengths can be flanged together.

## FLANGE ARRANGEMENTS

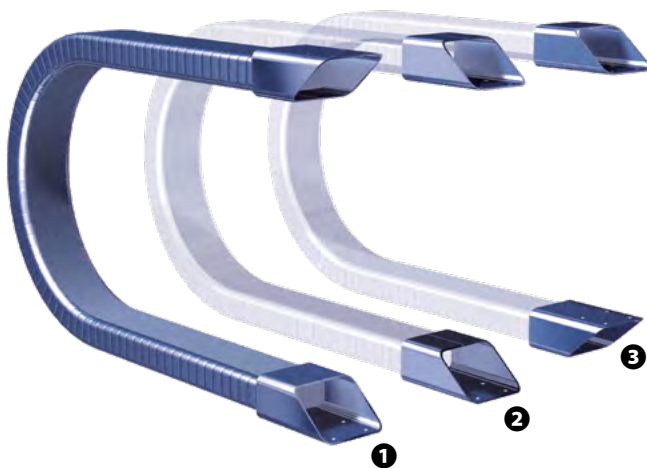

## functioning

- **h** horizontal
- **v** vertical standing
- **w** vertical suspended
- **z** cross beam - top view

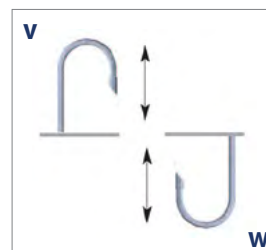
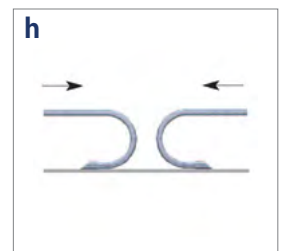

# STABIFLEX CABLE CARRIERS

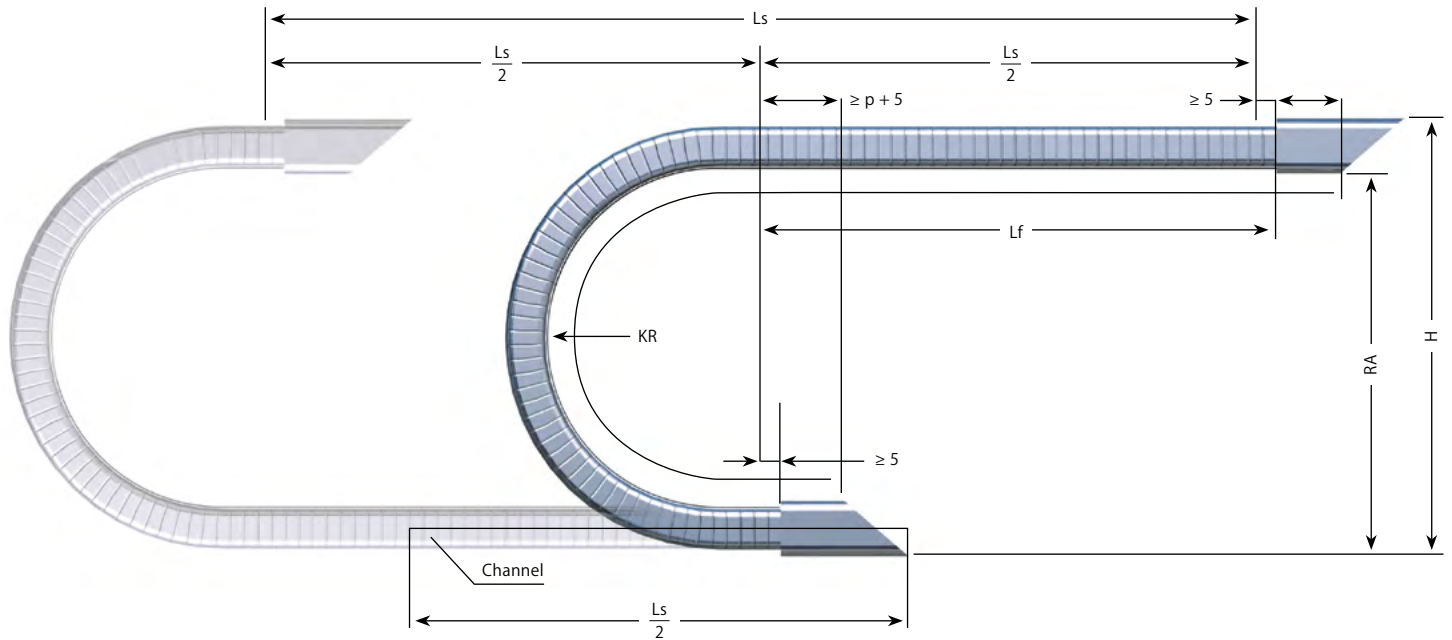

$$L = Ls/2 + 4KR + 50 \text{ (mm)}^*$$

$$L = Ls/2 + \pi KR Ls + 2p + 10 \text{ (mm)}^{**}$$

\* Approximate value

\*\* Formula used to calculate the precise length (rounded off to 10 mm)

## hose cross section

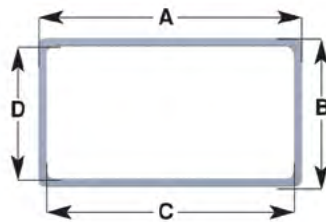

## legend

A x B = STABIFLEX - outside cross-section

C x D = STABIFLEX - inside cross-section

Lf = Unsupported length

L = STABIFLEX length

Ls = Travel

KR = Bending radius (Tolerance -20%)

H = Mounting height

p = Depth of conduit fitted in the flange

RA = Minimum height of support

Stabiflex Type	A	B	C	D	p	KR** +0° -20°	RA (Includes pre-load)	H	Lfmax	Ls without support	Ls with support	Weight hose kg/m	Weight flanges kg/Pair
0.0	30	20	26	16	25	55	120	144	1000	2000	4000	~ 0.6	~ 0.1
						720	160	194					~ 0.2
1.0	50	30	43	23	30	110	235	269	1500	3000	6000	~ 1.25	~ 0.2
						165	345	379					~ 0.3
1.1	50	50	45	45	50	110	240	294	2000	4000	8000	~ 1.7	~ 0.3
						110	240	290					~ 0.5
2.0	80	45	73	38	45	220	460	510	2000	4000	8000	~ 2.25	~ 0.5
						275	570	620					~ 0.6
2.1	85	60	80	55	65	165	350	415	2500	5000	10000	~ 2.4	~ 0.6
						130	280	335					~ 0.6
2.2	95	50	90	45	60	155	335	400	2000	4000	8000	~ 2.9	~ 0.6
						250	525	590					~ 1.0
3.0	110	60	102	52	60	330	685	750	2500	5000	10000	~ 3.6	~ 1.0
						220	465	550					~ 1.2
3.1	115	80	109	74	80	205	435	520	2500	5000	10000	~ 5.6	~ 1.7
						285	600	717					~ 3.9
4.0	170	80	162	72	80	205	435	520	2500	5000	10000	~ 5.6	~ 1.7
						285	600	717					~ 3.9
4.1	175	110	167	102	80	285	600	717	2500	5000	10000	~ 5.8	~ 3.9
						285	600	717					~ 3.9

# STABIFLEX CABLE CARRIERS

## STANDARD FLANGES

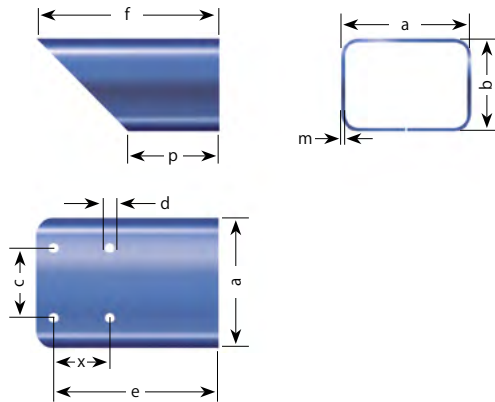

Type	a	b	c	d	e	f	p	m	x
0.0	34	24	13	6	40	50	25	1.5	-
1.0	54	34	22	7	45	60	30	1.5	-
1.1	54	54	20	7	75	100	50	1.5	-
2.0	85	50	50	7	67.5	90	45	2	-
2.1	90	65	50	7	117.5	130	65	2	40
2.2	100	55	50	7	110	120	60	2	40
3.0	115	65	70	9	90	120	60	2	-
3.1	120	85	80	9	142.5	165	80	2	40
4.0	175	85	100	9	120	160	80	2	-
4.1	182	117	140	9	157.5	195	80	3	40

## FACE FLANGE TYPE A

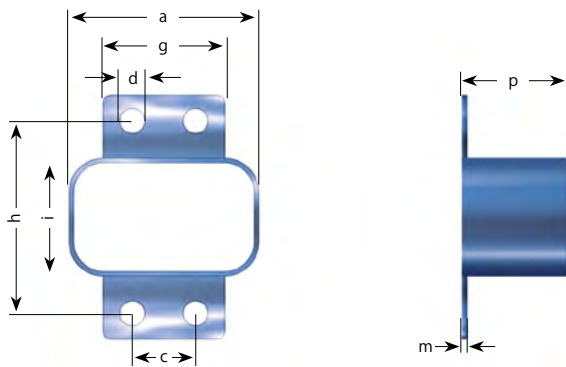

Type	a	b	c	d	g	h	i	p	m
1.0	54	34	18	7	35	70	55	30	1.5
2.0	85	50	45	7	65	85	70	45	2
3.0	115	65	60	9	80	110	90	60	2
4.0	175	85	95	9	120	130	110	80	2



## FACE FLANGE TYPE B

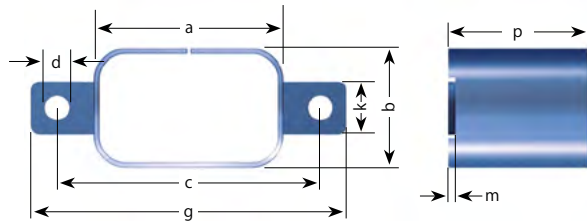

Type	a	b	c	d	g	k	p	m
1.0	54	34	75	7	90	15	30	1.5
2.0	85	50	105	7	120	30	45	2
3.0	115	65	140	9	160	35	60	2
4.0	175	85	200	9	220	40	80	2

## FACE FLANGE TYPE C

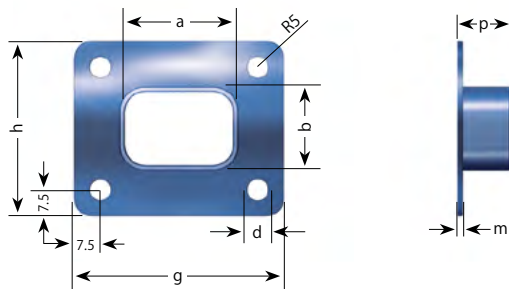





Type	a	b	d	g	h	p	m
0.0	34	24	6	60	50	25	1.5
1.1	54	54	7	85	85	50	1.5
2.1	90	65	7	120	95	65	2
2.2	100	55	7	130	85	60	2
3.1	120	85	9	150	115	80	2
4.1	182	117	9	210	145	80	3

# HENNIG WORLDWIDE | FACILITIES & CONTACTS

## ||| HENNIG®

Making our customers successful.

-  Headquarters / Manufacturing / Distribution / Service Center
-  Manufacturing / Distribution / Service Center
-  Manufacturing / Distribution
-  Sales Partner
-  Service Center

**1 Hennig, Inc. Global Headquarters**  
9900 North Alpine Road  
Machesney Park, IL 61115  
P: + 01 815-636-9900  
F: + 01 815-636-1988  
info@hennig-inc.com

**2 Hennig, Inc. Oklahoma Service Center**  
900395 S. 3420 Road  
Chandler, OK 74834  
P: + 01 405-258-6702  
F: + 01 405-258-9971  
info@hennig-inc.com

**3 Hennig, Inc. Michigan Service Center**  
11879 Brookfield Road  
Livonia, MI 48150  
P: + 01 734-523-8274  
F: + 01 855-427-1549  
info@hennig-inc.com

**4 Hennig, Inc. Ohio Service Center**  
11431 Williamson Road  
Blue Ash, OH 45241  
P: + 01 513-247-0838  
F: + 01 513-247-0840  
info@hennig-inc.com

**5 Hennig / Gaden, S.A. de C.V.**  
Calzada Abastos N° 235  
Col. Santa María  
Torreón Coahuila, C.P. 27020  
P: + 01 (871) 268 2449  
F: + 01 (871) 268 2449  
ventas@grupogaden.com

**6 Hennig / Gaden, S.A. de C.V.**  
Calle Primera N° 1037  
Col. Ministro Nazario Ortiz  
Saltillo, Coahuila, C.P. 25100  
P: + 01 (844) 180 0294  
F: + 01 (844) 180 029  
ventas@grupogaden.com

**7 Hennig / Gaden, S.A. de C.V.**  
Silca N° 4, Col. Vista Hermosa  
Tlalnepantla, Mexico, C.P. 54080  
P: + 52 (55) 5318 4146  
F: + 52 (55) 5319 32  
ventas@grupogaden.com

**8 Cobsen Ltda.**  
R. Benedito Mazulquim, 425  
18550-000 Boituva CEP, Brazil  
P: + 55 15 3263-4042  
F: + 55 15 3263-4070  
cobsen@cobsen.com.br



**9 Hennig GmbH European Headquarters**  
Überrheinerstrasse 5  
D-85551 Kirchheim, Germany  
P: + 49 89 96096-0  
F: + 49 89 96096-120  
info@hennig-gmbh.de

**10 Hennig CZ s.r.o.**  
Klánovická 334  
250 82 Úvaly, Czech Republic  
P: + 420 2810 91610  
F: + 420 2810 91625  
info@hennig-cz.com

**11 Hennig France sas (formerly Sermeto)**  
19, rue de Rebrillon  
03300 Creuzier-le-Neuf, France  
P: +33 470 58 4740  
F: + 33 470 58 0022  
contact@hennig-france.com

**12 Hennig U.K. Ltd.**  
Unit 6, Challenge Close  
Coventry CV1 5JG, United Kingdom  
P: + 44 24 76555690  
F: + 44 24 76256591  
sales@henniguk.com

**13 Hennig BH doo.**  
Ciljuge II bb - poslovna zona  
75270 Zivinice, Bosnia Hercegovina  
P: + 387 35 95 1876  
info@hennig-gmbh.de

**14 B & S Industrieel Onderhoud**  
Zirkoonstraat 7, 7554 TT Hengelo (Ov.)  
Postbus 69  
7550 AB Hengelo (Ov.), Netherlands  
P: + 31 74 8510600  
F: + 31 74 8510605  
megen@bs.nl

**15 Svenska Maskinkomponenter AB**  
Brunnsäkersvägen 9  
64593 Strängnäs, Sweden  
P: + 46 8 53470770  
F: + 46 8 53470775  
info@svemako.se

**16 Lubrication Equipment Pty. Ltd.**  
6, Liebenberg Road, South Africa  
1451 Alrode, Johannesburg  
P: + 27 11 8645785  
F: + 27 11 8648231  
sales@lubrequip.co.za

**17 Osung Mechatronics Co. Ltd.**  
Jinbuk-myun Shincon-li 413-2  
Gyungnam Masan-City, South Korea  
P: + 82 55 271 1821  
F: + 82 55 271 1820  
osgijeon@naver.com

**18 Enomoto BeA Co. Ltd.**  
5-10 Sohara Koa-Cho  
Kakamigahara-Shi,  
Gifu 504-8551, Japan  
P: + 81 583 832178  
F: + 81 583 897435  
kashida@enomotoweb.com

# MAKING OUR CUSTOMERS SUCCESSFUL

For over 65 years, Hennig Worldwide has been defining Excellence in Machine Protection, creating regional jobs, serving their local communities, and supporting the global needs of machine tool customers.

Specializing in chip management, machine protection, facility safety, and generator enclosures, Hennig products optimize production and keep your facility clean and safe.

## MACHINE PROTECTION

Telescopic Steel Covers  
Modular Face Shields (XYZ Shields)  
Bellows  
Aprons & Roll Up Covers  
Walk-On Covers  
Wiper Systems  
Telescopic Springs  
Cable Conduits

## CHIP SOLUTIONS

Chip Conveyors  
Turnkey Chip Management  
Conveyor Networks  
Chip Disc Filtration (CDF)  
Coolant Filtration  
Coolant Tanks

## ENCLOSURES & FACILITY SAFETY

GENSET Enclosures  
Machine Enclosures  
Platforms and Stairs  
Guarding and Fencing  
3D Printer Enclosures  
Additive Manufacturing Enclosures  
Walk-On Pit Covers  
Scissor Lift Bellows  
Machine Roof Bellow Covers  
Special Fabrications



Data Subject To Change    CC 0121    Printed in the USA    Copyright 2021

# ||| HENNIG®

Making our customers successful.

[www.hennigworldwide.com](http://www.hennigworldwide.com)